

Marine Catalogue

2014-15



www.vdo.net.au

Viewline—the new generation in instrumentation

- ◆ **Navigation Instruments**
- ◆ **Tachometer & Tachourmeter**
- ◆ **Gauges for engine monitoring**

VDO

New

Coming soon!

ProViu™ ASL360



Four Fisheye Cameras



ECU

Features:

- Four-Camera Surround View Driver Assistance enables the driver to see 360° around the boat/yacht on display.
- The surroundings can be seen top-down from a bird's eye view perspective. Such a view eliminates blind spots during critical and precise manoeuvres in different situations.
- Input images from the cameras are processed and stitched together in 360° bird-view of the boat/yacht surroundings
- Genuine real time delivery at 30fps
- Flexible SW tool chain (e.g. multiple screens, configuration, custom user interface etc.)
- Wide angle fisheye cameras

Example: https://www.youtube.com/watch?feature=player_detailpage&v=LwQCUeud2ZY



Viewline Gauges Index

Description	Notes	Diameter	Page
Viewline Gauges Introduction			4 - 10
Navigation Gauges - Wind	Wind Speed & Direction , Close Haul	80/85mm	11
Navigation Gauges	Depth Sounder - Sulog - Compass	80/85mm	12
Tachourmeter	Tachourmeter 3000, 4000, 5000, 6000 RPM	80/85mm	13
Tachometer	Tachometer 3000, 4000, 6000 RPM	80/85/52mm	14
Synchroniser	+ / - 500 RPM	80/85mm	14
Temp Gauge	Water, Oil, Transmission	52mm	15
Pyrometer	Exhaust Temp 100°C to 900°C	52mm	16
Temp Gauge Outside	Air Temp -25° to +50°C	52mm	17
Pressure Gauge	Turbo, Oil, Transmission	52mm	17 - 19
Fuel Level Gauge	Float Arm Type	52mm	20
Fuel Level Gauge	Reed Switch Type	52mm	21
Fuel Level Gauge	Tubular Type	52mm	22 - 23
Fuel Level Gauge	US Lever Type 240 - 33 Ohms	52mm	24
Fresh Water Level Gauge	Capacitance & Reed Switch Type	52mm	25
Waste/Grey Water Gauge	4-20 mA	52mm	26
Hourmeter	Engine Hours	52mm	26
Voltmeter	Battery Voltage	52mm	27
Ammeter	Ampere Meter 60 A and +150 A	52mm	27
Trim Gauge	Outboard Engine Trim	52mm	28
Rudder Angle Gauge	Rudder Position	52/80/85mm	28
Clock	Real Time Clock	52mm	28
Multifunction Gauges	Tacho,/Trim, Press. Fuel, Volt, Temp	110 mm	30 - 31
Sensors	Various sensors		32 - 36
Electrical Diagrams	Gauges connection (power and signals)		37 - 57
Gauges Accessories	Bezels - Plugs & Terminals - Tools		58 - 61
Fitting Instructions	Conventional & flush mount fittings		62 - 67
Calibration Instructions	Speedo, Tachourmeter & Tachometer		68 - 75



LCD display.

As well as having an analogue indication (speed or engine revs), the new Viewline tachometer and speedometer instruments have an additional digital display:

- ▶ Display size 37 mm x 11 mm
- ▶ Quick and reliable retrieval of other data
- ▶ Optimum reading angle and representation on the display
- ▶ Display with speed or engine revs (option)
- ▶ Further monitoring functions available on the LC display (e. g., battery, temperature, mileage indicator, etc.)
- ▶ Individual function selection via external button



Full backlight technology.

The dials and pointers of all Viewline instruments feature full backlight technology:

- ▶ Optimum contrast and superb readability of the display when lit
- ▶ Attractive display appearance at night thanks to clearly structured dial design



Combi and multifunction gauges*.

Now, in addition to the tried and tested standard solutions, Viewline also offers OEMs the option of installing multifunction devices:

- ▶ 85 mm combi devices, analogue and / or digital representation of speedometer and tachometer signals (OEM solution)
- ▶ 110 mm multifunction devices, such as 4-in-1, 2-in-1*
- ▶ Integration of up to five display / warning lights (OEM solution)

Signal inputs.

Viewline offers the following options for the signal inputs:

- ▶ NMEA 0183 data input for all navigation instruments
- ▶ Standard tachometer and speedometer signals
- ▶ Second frequency input (option)
- ▶ Standard signals for engine monitoring and on-board power supply
- ▶ Signal inputs for special sensors (option)
- ▶ Up to five usable switching inputs for control / warning lights within the OEM version (option)

Programmable displays.

Viewline enables the user to use different setting and programming options:

- ▶ Basic setup via dip switches, external button or a PC software package
- ▶ Setup of various display functions via external button



Introducing VDO Viewline

Our engineers started with a clean sheet of paper and a worldwide view to create an instrument line like no other in today's market. Their goal to create an instrument with flexibility, class and integrity something you've come to expect from VDO.

It begins with a fresh style and three choices of instrument sizes 100mm, 85mm and 52mm.

For styling, you have a choice of dial face colors of Black or White.

Next we added three choices of bezel styles along with two choices of bezel colors, white, black and chrome.

To complete your choices we give you three choices of instrument sizes 100mm, 85mm and 52mm giving you more flexibility than ever to create the instrument you are looking for.

They did not stop with just a pretty face, next they added integrity.

With the use of fully sealed dual lens, lifetime LED lighting and warning indicators assure you that Viewline can withstand even open cab environments easily.

Whether you are looking for standard or customized products, you are truly getting "more bang for your buck" with Viewline.

The VDO Heritage: **Reliability, durability and accuracy.**

Reliability

- IP67 water resistance means, that no matter how wet it gets, our gauges keep on working.
- Anti-corrosion materials mean no oxidation or rust will develop – Viewline will continue to work and look like new.

Accuracy

- VDO patented stepper motors and resistive movements.
- OEM derived technology in every instrument.

Durability

- CE certification.
- GL registered.
- UL94 flame resistance.
- Tested to 25 G continuous vibration and 100 G shock.
- 100% LED warning lights and telltales for long service life.

Viewline Gauges

Viewline is the new standardised instrument platform for pleasure boats and yachts. With modular solutions in three housing variations, we supply more functions, more flexible installation and design options as well as space-saving combi instruments – something unique in this sector.

All Viewline instruments can be conveniently mounted in the instrument panel.

Here, it is possible to use the modular bezels for installation as well as integrating the instruments flat without the bezels (flush installation).

This allows maximum flexibility in cockpit customisation and numerous design variants.



Viewline Gauges

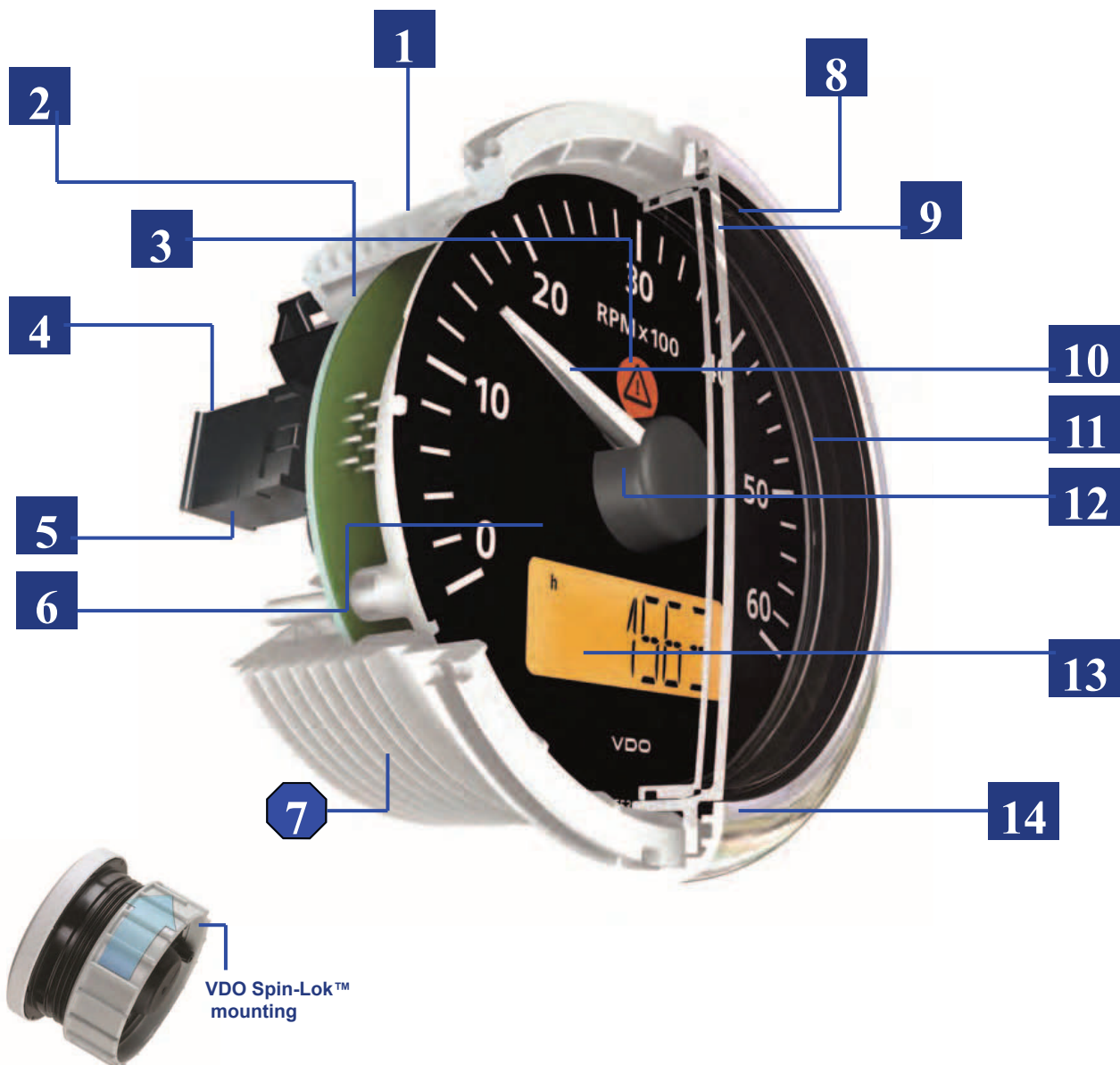

1. Spin-Lok mounting – a VDO innovation developed to safeguard against mounting panel warping and makes fast installation.
2. Single PCB increases reliability and minimizes instrument depth.
3. Built-in LED warning indicator (up to 5) is programmable to OEM-specified function.
4. Single cavity connectors reduce wiring installation time.
5. Reverse polarity and over voltage protection virtually eliminate the possibility of installation failures.
6. VDO is one of the few companies in the world to design, patent and manufacture stepper motors and resistive movements.
7. Corrosion-free and flame retardant materials comply with manufacturer's latest specifications.
8. Laser welded lenses ensure the highest level of protection against water intrusion.
9. Dual domed lenses eliminate fogging – another VDO innovation.
10. LED lit pointers and through dial lighting" minimize current consumption while optimizing nighttime viewing. "
11. Detail finish ring enhances the overall appearance of finished instrument – a VDO exclusive.
12. Designed to withstand continuous 25 G vibrations and 100 G single shock, to ensure maximum reliability of each instrument.
13. Large, multifunction backlit LCD provides easy readout of programmed functions.
14. Customer installed bezels with nine style choices allow for greater styling differentiation between product lines.

Viewline Gauges



Benefiting in the long-term from new technologies In developing the Viewline instrumentation, we have paid attention to the requirements of manufacturers. With Viewline, we have created a platform-wide standard with which we offer maximum freedom in respect of cockpit design.



Highly visible LED warning and indicator lights

Viewline instruments are fitted with highly visible, high intensity LED warning and indicator lights.

They ensure that critical operating conditions can be quickly and safely detected.

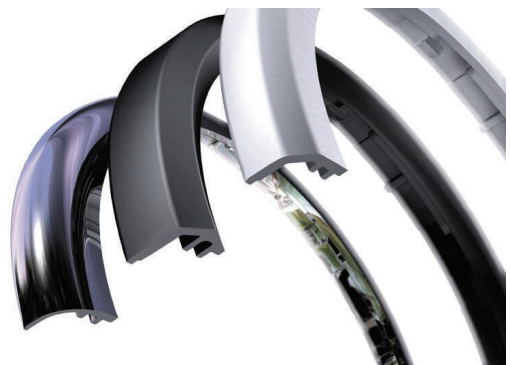

Clip-on bezel

The modular bezel concept offers design flexibility in the layout of instrument panels.

Three attractive design variants in black, white or chrome perfectly complement any boat's interior.

Furthermore, bezels are available in flat, round and triangular versions. All available bezels can be combined with all devices.

Viewline Gauges



Viewline Black



Viewline White



Apparent Wind - Maximum Wind Speed
Atmospheric Air Pressure - Ambient Temperature - Clock



Apparent Wind - Maximum Wind Speed
Atmospheric Air Pressure - Ambient Temperature - Clock
Voltmeter (when connected to an NMEA0183 PB100 or PB200 Sensor)



Loom p/n A2C59514545



Water Temperature - Depth - Shallow Water Alarm
Voltmeter - Clock (when connected to an NMEA0183 Depth Sensor)



Water Temperature - Depth - Compass Course - Course Over Ground
- GPS Time - Steering Aid - Voltmeter - Trip & Distance (when connected to an active NMEA0183 from a Paddle Wheel Sensor - GPS or Compass)

Loom p/n A2C59514544

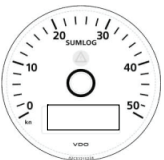

Wind Direction / Speed

Ø 80/85 mm

Part Number	Colour Dial/ Bezel	Range	Voltage
A2C59514245	Black	0 - 180° BB/SB	12/24V
A2C59514248	White	0 - 180° BB/SB	12/24V

Close Haul

Ø 80/85 mm

Part Number	Colour Dial/ Bezel	Range	Voltage
A2C59514246	Black	0 - 60° BB/SB	12/24V
A2C59514249	White	0 - 60° BB/SB	12/24V

Note: BB = Port SB=Star Board

Wind Speed / Direction Sensor

Part Number	Description	Voltage
X12719000129	Airmar Wind Speed & Direction Sensor	12/24V
A2C59514545	Short Loom connection to Wind, Close Haul and Sumlog	See page 40-41
X12719000131	Loom connection Airmar Wind Speed & Direction Sensor to A2C59514545 (Gauges)	See page 40-41

Depth - Water temp

Ø 80/85 mm

Part Number	Colour Dial/ Bezel	Range	Voltage
A2C59514247	Black	0 - 30	12/24V
A2C59514250	White	0 - 30	12/24V

Sumlog - Compass - COG - Steering Aid Ø 80/85 mm

Part Number	Colour Dial/ Bezel	Range	Voltage	Applicable Signal
A2C59514251	Black	12 Kn	12/24V	NMEA 0183
A2C59514252	Black	30 Kn	12/24V	NMEA 0183
A2C59514253	Black	50 Kn	12/24V	NMEA 0183
A2C59514254	Black	60 MPH	12/24V	NMEA 0183
A2C59514255	White	12 Kn	12/24V	NMEA 0183
A2C59514256	White	30 Kn	12/24V	NMEA 0183
A2C59514257	White	50 Kn	12/24V	NMEA 0183
A2C59514258	White	60 MPH	12/24V	NMEA 0183

Part Number	Colour Dial/ Bezel	Voltage
A2C59514544	Loom for Sumlog & Depth Transducer	12/24V NMEA 0183

For Sumlog & Depth Transducer see page 12



Transom Kit

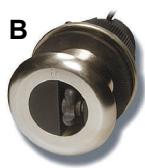

Through-Hull Kit

Transducer : Speed - Depth - Sea Water Temp

Part Number	Range	Description	Cable Length	Connector
1501120004	0 - 12 Kn	Transom Kit A	10 m	Blue White Red Black/Shield NMEA0183 + NMEA0183 - + 12/24V Negative
X11719000053	0 - 50 Kn	Transom Kit	10 m	Blue White Red Black/Shield NMEA0183 + NMEA0183 - + 12/24V Negative
X11719000058	0 - 50 Kn	Through-Hull Kit B	10 m	Blue White Red Black/Shield NMEA0183 + NMEA0183 - + 12/24V Negative
A2C59513503		Loom	0.3 m	Connection between Transducer p/n X11719000053 or p/n X11719000058 and Sumlog head.

- Speed
- Total & Trip Distance
- Depth
- Sea Water Temperature
- Clock
- Voltmeter
- External Trip-reset Button
- External Mode Button

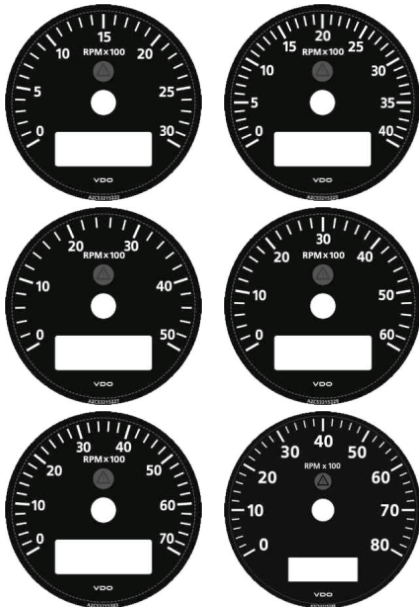

Tachourmeter

Ø 80/85 mm

Part Number	Colour Dial/ Bezel	Range	Voltage	Applicable Signal
A2C59512390	Black	0-3000 RPM	12/24V	Alternator Ignition Coil Generator Inductive
A2C59512391	Black	0-4000 RPM	12/24V	Alternator Ignition Coil Generator Inductive
A2C59512392	Black	0-5000 RPM	12/24V	Alternator Ignition Coil Generator Inductive
A2C59512393	Black	0-6000 RPM	12/24V	Alternator Ignition Coil Generator Inductive
A2C59512394	Black	0-7000 RPM	12/24V	Alternator Ignition Coil Generator Inductive
A2C59512395	Black	0-8000 RPM	12/24V	Alternator Ignition Coil Generator Inductive

Note: For all 270° meter movement deflection Viewline gauges' calibration, use Viewline Software adaptor cable & Software p/n A2C59514543.

- Engine Speed (RPM)
- Total & Trip Hours
- Clock
- Voltmeter
- External Trip-reset Button
- External Mode Button
- Programmable External Alarm

Tachourmeter & Tachometer

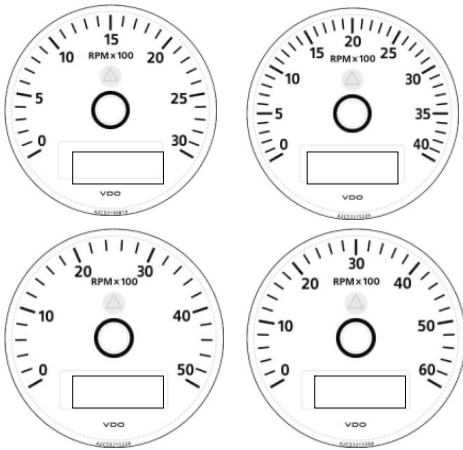

Tachourmeter Ø 80/85 mm

Part Number	Colour Dial/ Bezel	Range	Voltage	Applicable Signal
A2C59512396	White	0-3000 RPM	12/24V	Alternator, Ignition Coil Generator, Inductive
A2C59512397	White	0-4000 RPM	12/24V	Alternator Ignition Coil Generator Inductive
A2C59512398	White	0-5000 RPM	12/24V	Alternator, Ignition Coil Generator, Inductive
A2C59512399	White	0-6000 RPM	12/24V	Alternator Ignition Coil Generator Inductive

- Engine Speed (RPM)
- Total & Trip Hours
- Clock
- Voltmeter
- External Trip-reset Button
- External Mode Button
- Programmable External Alarm

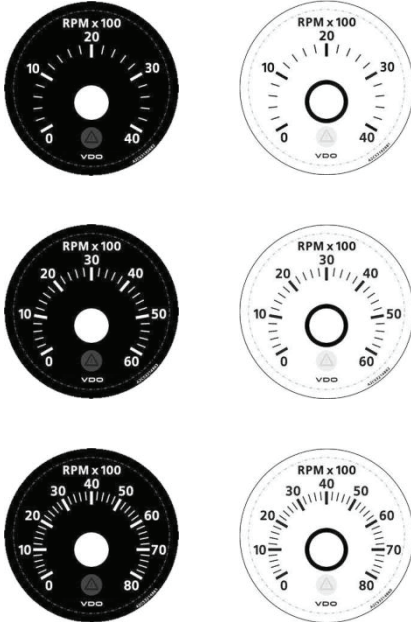

Engine Speed (RPM)



Tachometer Ø 52 mm

Part Number	Colour Dial/ Bezel	Range	Voltage	Applicable Signal
A2C59512344	Black	0-4000 RPM	12/24V	Alternator Ignition Coil (Note: Alternator signal calibration via software, only).
A2C59512345	Black	0-6000 RPM	12/24V	Alternator Ignition Coil (Note: Alternator signal calibration via software, only).
A2C59512346	Black	0-8000 RPM	12/24V	Alternator Ignition Coil (Note: Alternator signal calibration via software, only).
A2C59512347	White	0-4000 RPM	12/24V	Alternator Ignition Coil (Note: Alternator signal calibration via software, only).
A2C59512348	White	0-6000 RPM	12/24V	Alternator Ignition Coil (Note: Alternator signal calibration via software, only).
A2C59512349	White	0-8000 RPM	12/24V	Alternator Ignition Coil (Note: Alternator signal calibration via software, only).

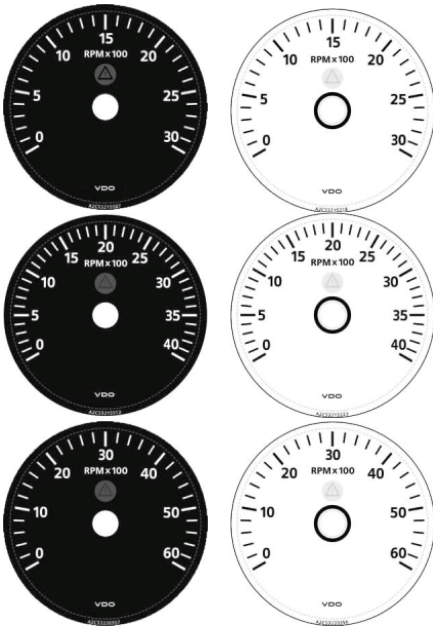

Tachometer				Ø 80/85 mm
Part Number	Colour Dial/ Bezel	Range	Voltage	Applicable Signal
A2C59512430	Black	0-3000 RPM	12/24V	Alternator Ignition Coil <small>(Note: Alternator signal calibration via software, only. Contact a VDO Service Agent for assistance)</small>
A2C59512431	Black	0-4000 RPM	12/24V	Alternator Ignition Coil <small>(Note: Alternator signal calibration via software, only. Contact a VDO Service Agent for assistance)</small>
A2C59512432	Black	0-6000 RPM	12/24V	Alternator Ignition Coil <small>(Note: Alternator signal calibration via software, only. Contact a VDO Service Agent for assistance)</small>
A2C59512433	White	0-3000 RPM	12/24V	Alternator Ignition Coil <small>(Note: Alternator signal calibration via software, only. Contact a VDO Service Agent for assistance)</small>
A2C59512434	White	0-4000 RPM	12/24V	Alternator Ignition Coil <small>(Note: Alternator signal calibration via software, only. Contact a VDO Service Agent for assistance)</small>
A2C59512435	White	0-6000 RPM	12/24V	Alternator Ignition Coil <small>(Note: Alternator signal calibration via software, only. Contact a VDO Service Agent for assistance)</small>

**Engine Speed (RPM)
Programmable Alarm (Software)**



Synchroniser Tachometer				Ø 80/85 mm
Part Number	Colour Dial/ Bezel	Range	Voltage	Applicable Signal
A2C59512402	Black	+/- 0-500 RPM	12/24V	Alternator Ignition Coil Generator Inductive
A2C59512403	White	+/- 0-500 RPM	12/24V	Alternator Ignition Coil Generator Inductive

Differential Engine Speed (RPM)

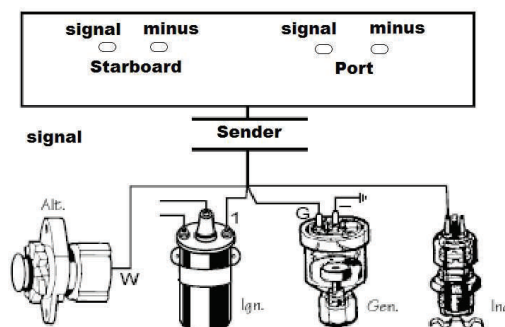

Temperature



Temperature Gauge Water Ø 52 mm

Part Number	Colour Dial/ Bezel	Range	Voltage	Ohms Range
A2C59514170	Black	40 - 120C (250F)	12/24V	282 - 22 Ohms 38.6 Ohms = 100C
A2C59514237	White	40 - 120C (250F)	12V/24V	282 - 22 Ohms 38.6 Ohms = 100C

Temperature Sender Water

Part Number	Range	Thread size	Connector
323805001001K	40 - 120C (250F)	M14x1.5	2 spade terminals
323805001015N	40 - 120C (250F)	M18x1.5	2 spade terminals
323805001004K	40 - 120C (250F)	1/2"-14NPTF	2 spade terminals
323805001005N	40 - 120C (250F)	3/8"-18NPTF	2 spade terminals
323805001002C	40 - 120C (250F)	5/8"-18UNF 2A	2 spade terminals



Note: For single terminals (earth return) or dual station senders, refer appendix on page 34 - 35



Temperature Gauge Engine Ø 52 mm

Part Number	Colour Dial/ Bezel	Range	Voltage	Ohms Range
A2C59514160	Black	50 - 150C (300F)	12V/24V	323 - 18 Ohms 62.2 Ohms = 100C
A2C59514231	White	50 - 150C (300F)	12V/24V	323 - 18 Ohms 62.2 Ohms = 100C

Temperature Sender Engine

Part Number	Range	Thread size	Connector
323805001001K	50 - 150C (300F)	M14x1.5	2 spade terminals
323805003002N	50 - 150C (300F)	1/4"-18NPTF	2 spade terminals



Note: For single terminals (earth return) or dual station senders, refer appendix on page 34 - 35



Pyrometer Gauge - Ø 52 mm

Part Number	Colour Dial/ Bezel	Range	Voltage	mV Range
A2C59512332	Black	100 - 900C (1650F)	12/24V	4.04 - 37.5 mV
A2C59512333	White	100 - 900C (1650F)	12/24V	4.04 - 37.5 mV
A2C59512334	Black	212 - 1650F (900C)	12/24V	4.04 - 37.5 mV
A2C59512335	White	212 - 1650F (900C)	12/24V	4.04 - 37.5 mV

Thermocouple K Type Kit (no gauge)



Part Number	Description	Range	Terminals
320.714	Thermocouple Probe	100 - 900C (1650F)	Red = Negative Yellow = Positive
240.035	Compensating Cable	5 metres	White = Negative Blue = Positive <u>or</u> Red = Negative Brown = Positive

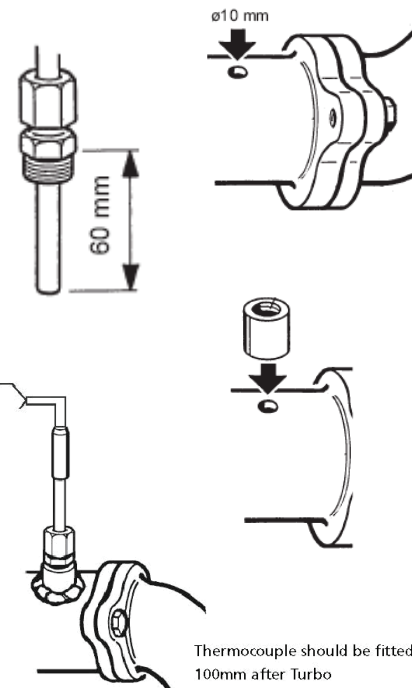

Install the sensor in the exhaust pipe near the elbow flange.

Maximum adjustment depth up to the middle of exhaust pipe: 60 mm.

Mount the bushing centrally and weld on.

The weld must form a tight seal.

K Type thermocouple Calibration Chart

Degrees Celsius	Probe Voltage (mV)
100	4.04
200	8.137
300	12.20
400	16.4
500	20.64
600	24.902
700	29.128
800	33.277
900	37.325

Celsius to Fahrenheit Conversion Chart

Degrees Celsius	Degrees Fahrenheit
100	212
200	392
300	572
400	752
500	932
600	1112
700	1292
800	1472
900	1650

Outside Temp & Turbo Pressure



Outside Air Temperature

Ø 52 mm

Part Number	Colour Dial Bezel	Range	Voltage	Ohms
A2C59512336	Black	-25to+50C	12/24V	0°C = 4082 Ohms
A2C59510431	White	-25to+50C	12/24V	0°C = 4082 Ohms

Temperature Sender Air

Part Number	Range	Cable Length	Wires
323809010005	-25to+50C	L = 3000mm	Green Signal Brown Negative

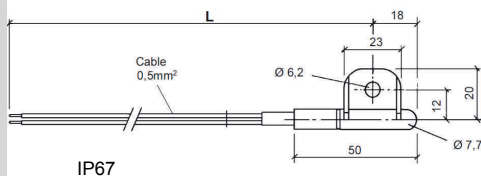

Pressure Gauge Turbo 2 Bar

Part Number	Colour Dial/ Bezel	Range	Voltage	Ohms Range
A2C59514149	Black	0 - 2 Bar (28 Psi)	12/24V	10 - 183 Ohms 0-2 Bar
A2C59514225	White	0 - 2 Bar (28 Psi)	12/24V	10 - 183 Ohms 0-2 Bar

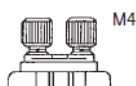

Pressure Sender 2 Bar

Part Number	Range	Thread size	Connector
360081032025C	0 - 2 Bar (28 Psi)	1/8"-27NPTF	2 x M4 Screws
360081032011C	0 - 2 Bar (28 Psi)	M12x1.5	2 x M4 Screws

Note: For single terminals (earth return) or dual station senders, refer to pages 32 - 33

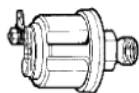

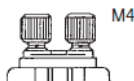
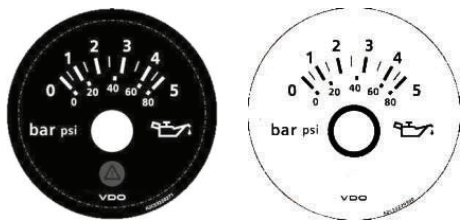

Pressure Gauge Engine Oil Ø 52 mm

Part Number	Colour Dial Bezel	Range	Voltage	Ohms Range
A2C59514123	Black	0 - 5 Bar (72 Psi)	12/24V	0 Bar = 10 5 Bar = 183
A2C59514211	White	0 - 5 Bar (72 Psi)	12/24V	0 Bar = 10 5 Bar = 183

Pressure Sender Engine Oil

Part Number	Range	Thread size	Connector
360081032002C	0 - 5 Bar (72 Psi)	M10x1	2 Screw terminals
360081032001C	0 - 5 Bar (72 Psi)	1/8"-27NPTF	2 Screw terminals

Note: For single terminals (earth return) or dual station senders, refer to pages 32- 33

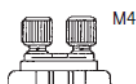
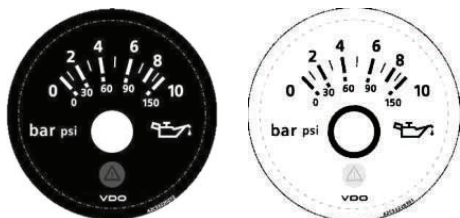
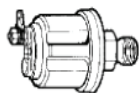

Pressure Gauge Engine Oil Ø 52 mm

Part Number	Colour Dial Bezel	Range	Voltage	Ohms Range
A2C59514111	Black	0 - 10 Bar (150 Psi)	12/24V	0 Bar = 10 10 Bar = 183
A2C59514199	White	0 - 10 Bar (150 Psi)	12/24V	0 Bar = 10 10 Bar = 183

Pressure Sender Engine Oil

Part Number	Range	Thread size	Connector
360081032003C	0 - 10 Bar (150 Psi)	M10x1	2 Screw terminals
360081032006C	0 - 10 Bar (150 Psi)	M14x1.5	2 Screw terminals
360081032014C	0 - 10 Bar (150 Psi)	1/8"-27NPTF	2 Screw terminals

Note: For single terminals (earth return) or dual station senders, refer to pages 32- 33

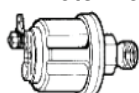

Transmission Pressure

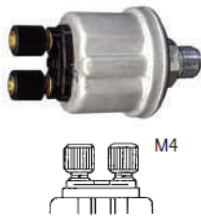
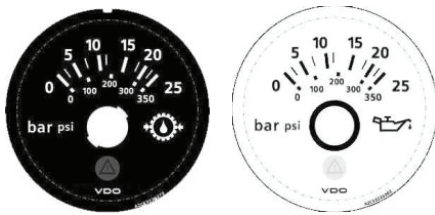

Pressure Gauge Transmission Ø 52 mm

Part Number	Colour Dial Bezel	Range	Voltage	Ohms Range
A2C59514136	Black	0 - 25 Bar (400 Psi)	12/24V	0 Bar = 10 25 Bar = 183
A2C59514206	White	0 - 25 Bar (400 Psi)	12/24V	0 Bar = 10 25 Bar = 183

Pressure Sender Transmission

Part Number	Range	Thread size	Connector
360081038001C	0 - 25 Bar (400 Psi)	M14x1.5	2 Screw terminals
360081038003C	0 - 25 Bar (400 Psi)	1/8"-27NPTF	2 Screw terminals
360081038002C	0 - 25 Bar (400 Psi)	3/8"-18NPTF	2 Screw terminals

Note: For single terminals (earth return) or dual station senders, refer to pages 32 - 33

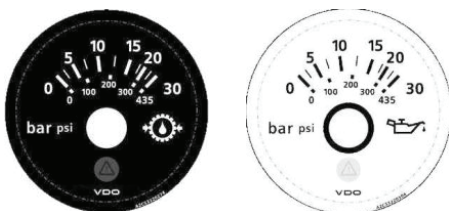
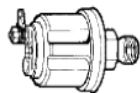

Pressure Gauge Transmission Ø 52 mm

Part Number	Colour Dial Bezel	Range	Voltage	Ohms Range
A2C59514141	Black	0 - 30 Bar (435 Psi)	12/24V	0 Bar = 10 30 Bar = 183
A2C59514208	White	0 - 30 Bar (435 Psi)	12/24V	0 Bar = 10 30 Bar = 183

Pressure Sender Transmission

Part Number	Range	Thread size	Connector
360081038001C	0 - 30Bar (435 Psi)	M14x1.5	2 Screw terminals
360081038003C	0 - 30Bar (435 Psi)	1/8"-27NPTF	2 Screw terminals
360081038002C	0 - 30 Bar (435 Psi)	3/8"-18NPTF	2 Screw terminals

Note: For single terminals (earth return) or dual station senders, refer to pages 32 - 33

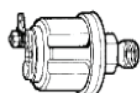

***For 30 Bar pressure sender's range, use 25 Bar senders**



Fuel Gauge

Ø 52 mm

Part Number	Colour Dial Bezel	Range	Voltage	Ohms Range
A2C59514082	Black	0 - 1	12/24V	Empty = 3 Full = 180
A2C59514184	White	0 - 1	12/24V	Empty = 3 Full = 180

Sender Float Arm - Fuel Pitch 54 mm

Part Number	Range	Notes	Terminal
226801015001C	3-180 Ohms	Adjustable 200-600mm	Spade x2
N02240106	5-90 Ohms	Adjustable 200-600mm	Spade x2
A2C59510165	3-180 Ohms	Sender with low fuel warning switch. Adjustable 150-535mm	Spade x3
A2C59510171	3-180 Ohms	Arm Type Fuel Sender Adjustable 150-535mm	Spade x2
A2C59510166	240-33 Ohms	Sender with low fuel warning switch. Adjustable 150-535mm	Spade x3
A2C59510172	240-33 Ohms	Arm Type Fuel Sender Adjustable 150-535mm	Spade x2
A2C59510167	5-90 Ohms	Sender with low fuel warning switch. Adjustable 150-535mm	Spade x3
A2C59510173	5-90 Ohms	Arm Type Fuel Sender Adjustable 150-535mm	Spade x2

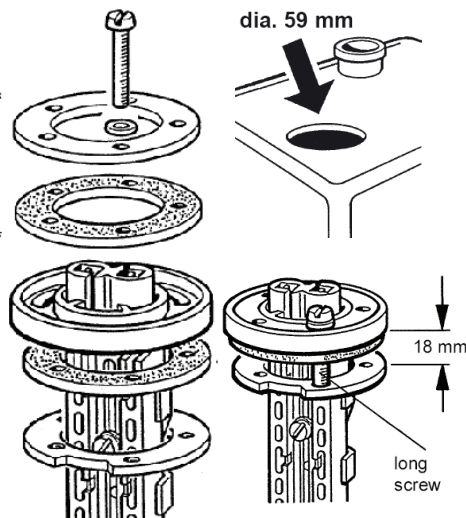
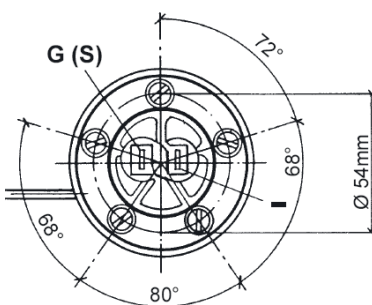
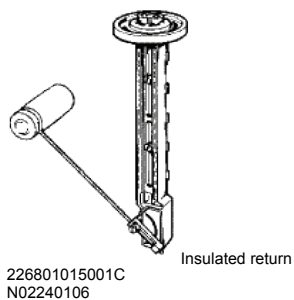

with slit must be inserted first

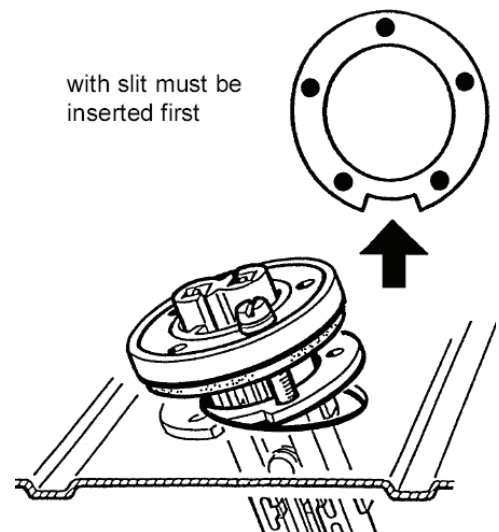

Note: Use adaptor plate p/n **CTA0200KIT** when installing the five holes sender's plate on to 6 holes applications.



Fuel Gauge Ø 52 mm

Part Number	Colour Dial Bezel	Range	Voltage	Ohms Range
A2C59514082	Black	0 - 1	12/24V	Empty = 3 Full = 180
A2C59514184	White	0 - 1	12/24V	Empty = 3 Full = 180

Note: All Reed Switch senders on the list below have a Low Fuel Warning switch, except the 150 & 180 mm length (marked *)

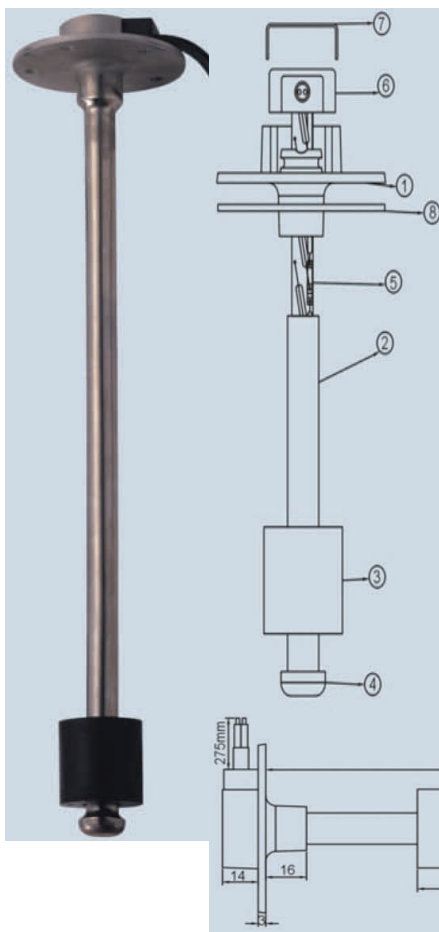

Sender Reed Switch - Fuel Pitch 54 mm

Part Number	Range E - F	L = length
220.150-180	3-180 Ohms	150 mm *
220.180-180	3-180 Ohms	180 mm *
220.230-180	3-180 Ohms	230 mm
220.250-180	3-180 Ohms	250 mm
220.260-180	3-180 Ohms	260 mm
220.270-180	3-180 Ohms	270 mm
220.300-180	3-180 Ohms	300 mm
220.320-180	3-180 Ohms	320 mm
220.330-180	3-180 Ohms	330 mm
220.350-180	3-180 Ohms	350 mm
220.600-180	3-180 Ohms	600 mm
220.660-180	3-180 Ohms	660 mm

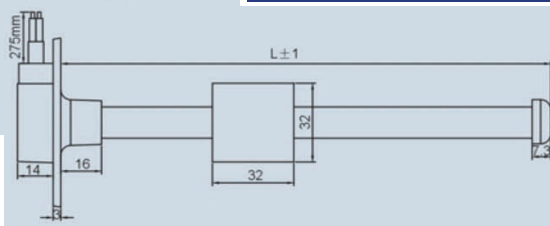

Item #	Qty	Description	Material
1	1	Sensor Head	S/Steel 316
2	1	Reed Sw Tube	S/Steel 316
3	1	Float 32x32mm	Acrylon NBR
4	1	Bottom plug	S/Steel 316
5	1	Reed Sw assy	NBR 60
6	1	Rubber	
7	1	Cover	Alum
8	1	Gasket 68x2mm	NBR 60

Note: Use adaptor plate p/n **CTA0200KIT** when installing the five holes sender's plate on to 6 holes applications.

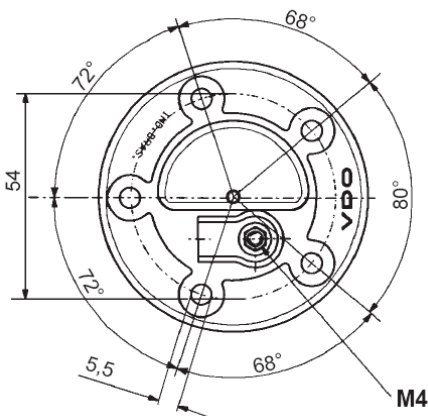

Fuel Gauge Tubular Type

Part Number	Colour Dial Bezel	Range	Voltage	Ohms Range
A2C59514088	Black	0 - 1/1	12/24V	Empty = 110 / 50 Full = 2
A2C59514182	White	0 - 1/1	12/24V	Empty = 110 / 50 Full = 2

Sender Tubular Type - Fuel Pitch 54 mm

Sender Part No.	Length	Sender Part No.	Length
224011000015G	150mm	224011000032G	320mm
224011000016G	160mm	224011000033G	330mm
224011000017G	170mm	224011000034G	340mm
224011000018G	180mm	224011000035G	350mm
224011000019G	190mm	224011000036G	360mm
224011000020G	200mm	224011000037G	370mm
224011000021G	210mm	224011000038G	380mm
224011000022G	220mm	224011000039G	390mm
224011000023G	230mm	224011000040G	400mm
224011000024G	240mm	224011000045G	450mm
224011000025G	250mm	224011000050G	500mm
224011000026G	260mm	224011000055G	550mm
224011000027G	270mm	224011000060G	600mm
224011000028G	280mm	224011000065G	650mm
224011000029G	290mm	224011000070G	700mm
224011000030G	300mm	224011000075G	750mm
224011000031G	310mm	224011000080G	800mm

Note: To replace a 80mm to 54 mm pitch diameter sender use flange kit p/n **CTA0202KIT**

dia. 59 mm

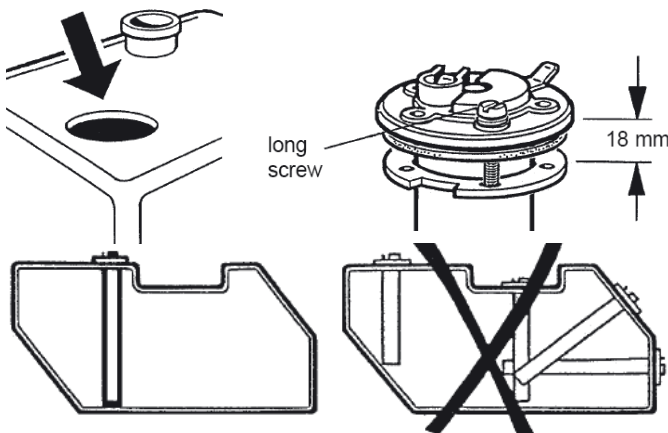

with slit must be inserted first

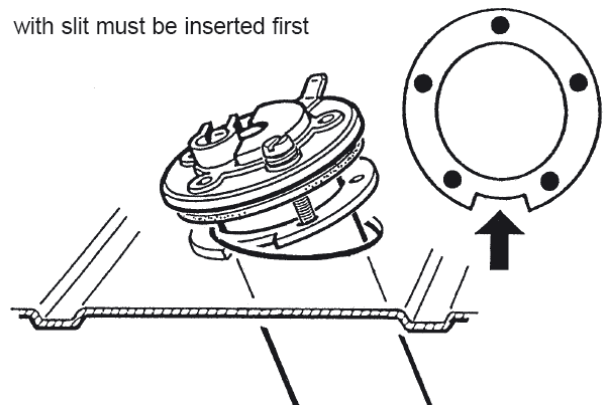



Fuel Gauge Tubular Type

Part Number	Colour Dial Bezel	Range	Voltage	Ohms Range
A2C59514088	Black	0 - 1/1	12/24V	Empty = 110 / 50 Full = 2
A2C59514182	White	0 - 1/1	12/24V	Empty = 110 / 50 Full = 2



Accessories:

p/n 115910011401 Welding Flange Ø80mm
p/n 2251016 Gasket Cork Ø80mm

Sender Tubular Type - Fuel Pitch 80 mm

Sender Part No.	Length	Sender Part No.	Length
X10224014031	326 mm	X10224009026	831 mm
X10224014021	426 mm	X10224021006	846 mm
X10224009037	536 mm	X10224014003	881 mm
X10224009053	551 mm	X10224014011	916 mm
X10224009039	596 mm	X10224009057	946 mm
X10224021002	596 mm	X10224014015	996 mm
X10224014022	616 mm	X10224009022	1001 mm
X10224009048	641 mm	X10224021005	1045 mm
X10224014002	686 mm	X10224009040	1086 mm
X10224009029	741 mm	X10224014044	1250 mm
X10224009019	781 mm	X10224009072	1387 mm
X10224021004	803 mm	-----	-----

Note: To replace a 80mm to 54 mm pitch diameter sender use flange kit p/n **CTA0202KIT**

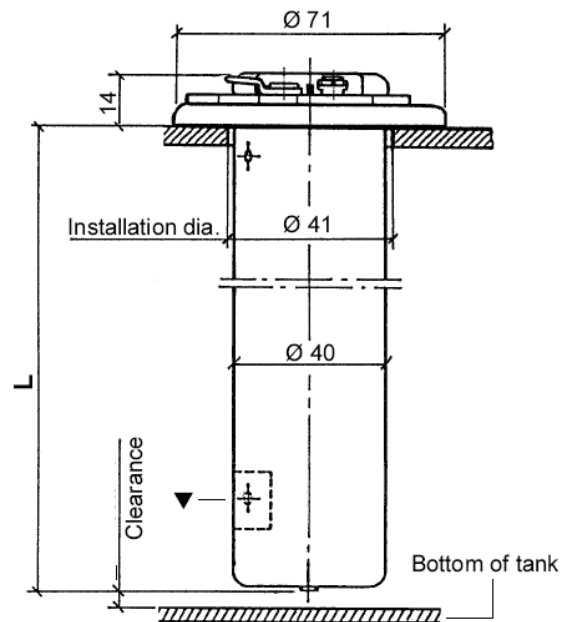
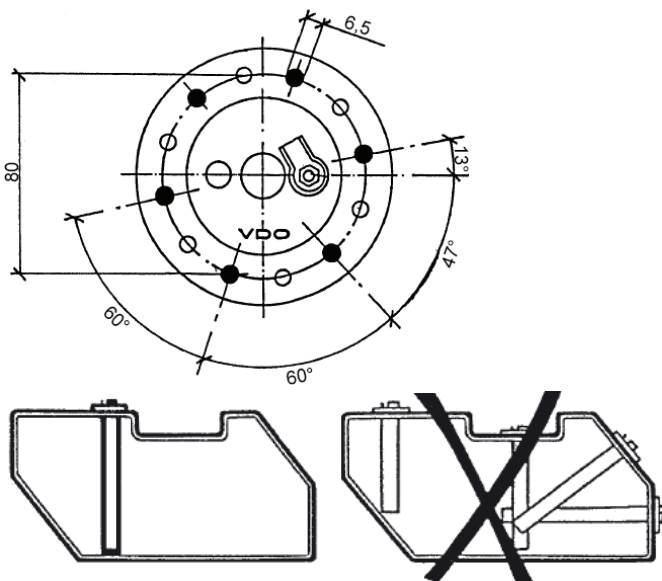

Fuel Gauge - US Senders



Fuel Gauge (US Application)				Ø 52 mm
Part Number	Colour Dial / Bezel	Range	Voltage	Ohms Range
A2C59514085	Black	E -1/2 - F	12/24V	Empty = 5 Full = 90
A2C59514186	White	E -1/2 - F	12/24V	Empty = 5 Full = 90
A2C59514094	Black	E -1/2 - F	12/24V	Empty= 240 Full = 33
A2C59514190	White	E -1/2 - F	12/24V	Empty= 240 Full = 33



Lever Fuel Sensor - without low fuel alarm			
Part Number	Ohms Range	Adjustable	Pitch Ø
220.004	5 - 90	145 - 400 mm	54 mm
220.005	240 -33	145 - 400 mm	54 mm



Lever Fuel Sensor - with low fuel alarm			
Part Number	Ohms Range	Adjustable	Pitch Ø
A2C59510166	240 - 33	145 - 400 mm	54 mm
A2C59510167	0 - 90	145 - 400 mm	54 mm

Lever Fuel Sensor - without low fuel alarm			
Part Number	Ohms Range	Ohms Range	Pitch Ø
A2C59510172	240 - 33	145 - 400 mm	54 mm
A2C59510173	0 - 90	145 - 400 mm	54 mm



Tank Sender Accessories	
Part No.	Description.
N05801432	Flange Kit Bolt Circle Ø54mm
22502641141	Bolt Circle Ø54mm
224011000017G	Bolt Circle Ø80mm
CTA0200KIT	Six to five holes conversion plate

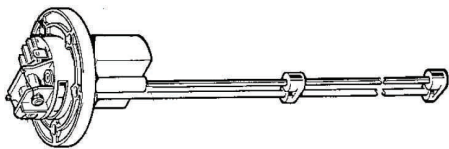
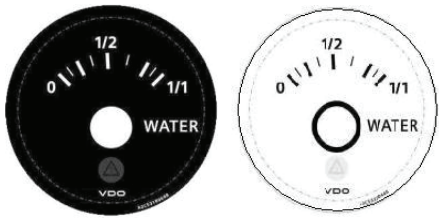

Fresh Water Level Gauge

Ø 52 mm

Part Number	Colour Dial Bezel	Range	Voltage	Range
A2C59514676	Black	0 - 1/1	12/24V	Empty = 4 mA Full = 20 mA
A2C59514677	White	0 - 1/1	12/24V	Empty = 4 mA Full = 20 mA

Fresh Water Sender 4 - 20 mA

Part Number	Range E - F	Adjustable length	Terminal
N02240402	0 - 100%	80 - 600 mm	Water-Proof Plug
N02240404	0 - 100%	600 - 1200 mm	Water-Proof Plug
N02240406	0 - 100%	1200 - 1500 mm	Water-Proof Plug

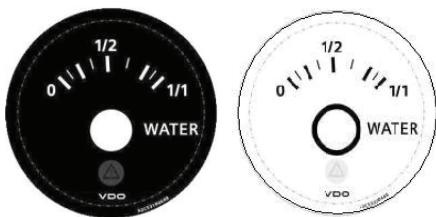

Fresh Water Level Gauge

Ø 52 mm

Part Number	Colour Dial Bezel	Range	Voltage	Range
A2C59514097	Black	0 - 1/1	12/24V	Empty = 3 Ohms Full = 180 Ohms
A2C59514192	White	0 - 1/1	12/24V	Empty = 3 Ohms Full = 180 Ohms

Sender Reed Switch - Water Pitch 54 mm

Part Number	Range E - F	L = length	Terminal
220.150-180	3-180 Ohms	150 mm	Water-Proof Plug
220.180-180	3-180 Ohms	180 mm	Water-Proof Plug
220.230-180	3-180 Ohms	230 mm	Water-Proof Plug
220.260-180	3-180 Ohms	260 mm	Water-Proof Plug
220.270-180	3-180 Ohms	270 mm	Water-Proof Plug
220.300-180	3-180 Ohms	300 mm	Water-Proof Plug
220.320-180	3-180 Ohms	320 mm	Water-Proof Plug
220.330-180	3-180 Ohms	330 mm	Water-Proof Plug
220.600-180	3-180 Ohms	600 mm	Water-Proof Plug
220.660-180	3-180 Ohms	660 mm	Water-Proof Plug



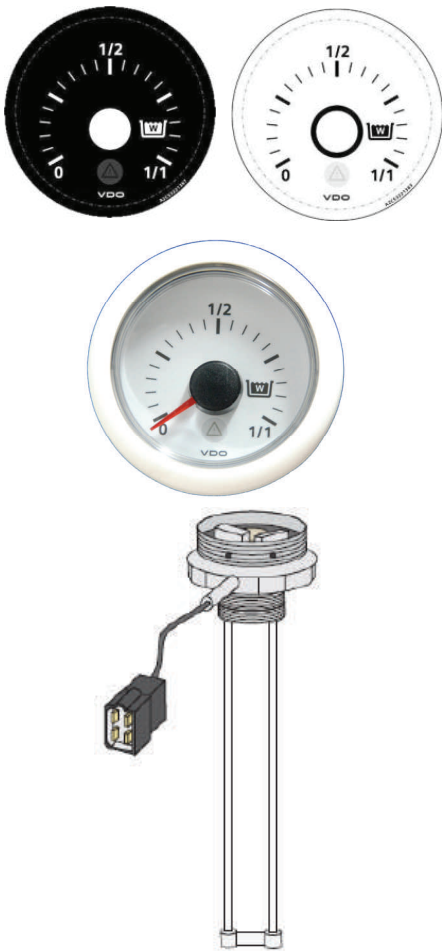

Waste Water Level Gauge				Ø 52 mm
Part Number	Colour Dial Bezel	Range	Voltage	Range
A2C59512342	Black	0 - 1/1	12/24V	Empty = 4 mA Full = 20 mA
A2C59512343	White	0 - 1/1	12/24V	Empty = 4 mA Full = 20 mA

Waste Water Sender			
Part Number	Range E - F	Adjustable length	Terminal
N02240902	Empty = 4 mA Full = 20 mA	80 - 600 mm	Water-Proof Plug
N02240904	Empty = 4 mA Full = 20 mA	600 - 1200 mm	Water-Proof Plug
N02240906	Empty = 4 mA Full = 20 mA	1200 - 1500 mm	Water-Proof Plug

Accessory	
Part Number	Description
X1022400007	Tank unit flange with Gasket

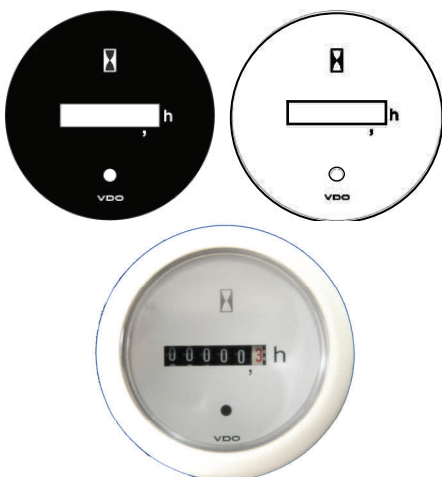

Hourmeter			
Part Number	Colour Dial/ Bezel	Light	Voltage
A2C59512453	Black	Yes	12/24V
A2C59512454	White	Yes	12/24V



Pressure Switch - Heavy Duty					
Part Number	Switch Point Bar (Psi)	Thread Size	Terminals	Picture	Switch Contact
230.050	0.5 Bar (7) Fixed	1/8"-27NPTF	Screw x 2 Insulated Return	A	N/O Raising Pressure

Volt & Ammeter



Voltmeter			Ø 52 mm
Part Number	Colour Dial / Bezel	Range	Voltage
A2C59512545	Black	8 -16V	12V
A2C59512546	White	8 -16V	12V
A2C59512458	Black	18 - 32V	24V
A2C59512459	White	18 - 32V	24V

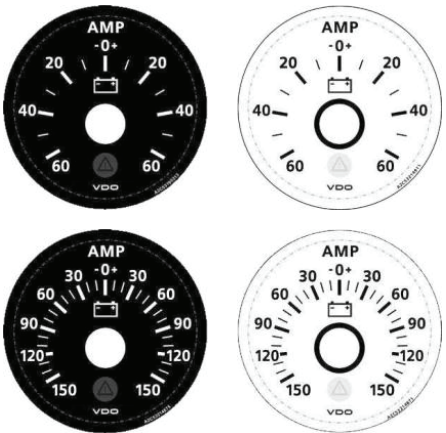

Ammeter Gauge with external shunt			Ø 52 mm
Part Number	Colour Dial / Bezel	Range	Voltage
A2C59512328	Black	60A	12/24V
A2C59512330	White	60A	12/24V
A2C59512329	Black	150A	12/24V
A2C59512331	White	150A	12/24V

Note: Above Gauge does not include the Shunt, Harness and Mounting Bracket



Order parts below to complete the kit:



Ammeter Shunt		
Part Number	Range / Description	Voltage
UK-UE-157	60A	12/24V
UK-UE-094	150A	12/24V
UK-UE-184	Shunt Harness	
UK-UE-188	Universal Mounting Bracket Kit	

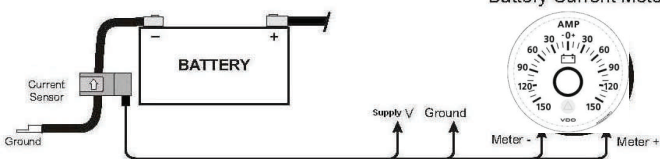

Battery Current Meter



SENSOR Specs

Sensor Type: Open loop Hall-Effect
 Linearity: 1.5%
 Supply Voltage Range: 12/24V
 Current Consumption: 8.1 mA max
 Output to Gauge: + - 60 mV
 Operating Temp: 40°C to + 125°C
 Storage Temp: 40°C to + 125°C
 Aperture size: 31.24 mm
 Weight: 0.136 Kg
 Connector: Packard sealed Metri-Pak 150
 Note: Mating plug not supplied with sensor



Trim Gauge Ø 52 mm

Part Number	Colour Dial/ Bezel	Range	Voltage
A2C59514180	Black	Bravo Drive	12/24V
A2C59514244	White	Bravo Drive	12/24V



Rudder Angle Indicator Ø 52 mm

Part Number	Colour Dial/ Bezel	Range	Voltage
A2C59514154	Black	40° Stb	12/24V
A2C59514230	White	40° Stb	12/24V



Rudder Angle Indicator Ø 80/85 mm

Part Number	Colour Dial/ Bezel	Range	Voltage
A2C59512410	Black	+45°	12/24V
A2C59512411	White	+45°	12/24V



Rudder Angle Sender

Part Number		Voltage	Note
440102001001D	Single Station	12/24V	Sender suitable for 52 and 85mm gauges
440102002001D	Dual Station	12/24V	Dual station sender has a "D" market on the body

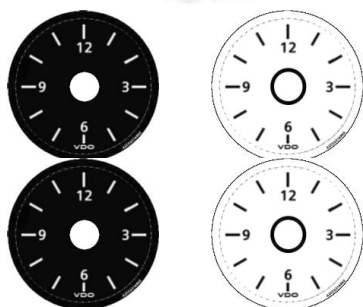

Clock Ø 52 mm

Part Number	Colour Dial/ Bezel	Range	Voltage
A2C59513445	Black	12h	12V
A2C59513443	White	12h	12V
A2C59513446	Black	12h	24V
A2C59513444	White	12h	24V









Warning Lights



Note: the above Warning Light pictures are only as example

Features

- LED illumination
- Backlit technology
- Changeable bezels
- Anti-fog and splash protection
- Panel and flush mount possibility

Warning Light Gauge		12V	Ø 52 mm
Part Number	Colour Dial/ Bezel	Warning Lights ISO Symbols	Function & Colour
A2CFR017005	White		
A2CFR017006	Black		
			Low Fuel Yellow
			Water Temp Red
			Battery Red
			Engine Oil Pressure Red
			Engine Oil Temp Red
			Glow Plug On Yellow

Multifunction Gauges



Tacho - Trim

Ø 110 mm

Part Number	Colour Dial/ Bezel	Range	Voltage
A2C59514259	Black	0 - 6000 RPM Trim for Mercury Bravo Drive sensor	12/24V
A2C59514260	White	0 - 6000 RPM Trim for Mercury Bravo Drive sensor	12/24V
A2C59514261	Black	0 - 7000 RPM Trim for Mercury Bravo Drive sensor	12/24V
A2C59514262	White	0 - 7000 RPM Trim for Mercury Bravo Drive sensor	12/24V
A2C59514263	Black	0 - 8000 RPM Trim for Mercury Bravo Drive sensor	12/24V
A2C59514264	White	0 - 8000 RPM Trim for Mercury Bravo Drive sensor	12/24V



Pitot Tube Speedo - Fuel Tank Level Ø 110 mm

Part Number	Colour Dial/ Bezel	Range	Voltage
A2C53406160	Black	Range: 10 - 80 Km/h Fuel: 3 - 180R	12V
A2C53406159	White	Range: 10 - 80 Km/h Fuel: 3 - 180R	12V
170.702		Pitot Tube Foot Kit	

Sender - Fuel

3 - 180 Ohms Fuel Level Sender (See pages 20 & 21 for p/n's)

170.702 Kit



Multifunction Gauges



4 in one Gauges

Ø 110 mm

Part Number	Colour Dial/ Bezel	Range	Voltage
A2C59514265	Black	Volt 8 -16V- Pressure 0 - 5 Bar Temp 40 - 120C Fuel E - F	12V
A2C59514266	White	Volt 8 -16V- Pressure 0 - 5 Bar Temp 40 - 120C Fuel E - F	12V

Features

- LED illumination
- 5 Integrated Warning-LEDs
- Backlight technology
- Changeable bezels
- Antifog and splash protection



Pressure Sender Engine Oil

Part Number	Range	Thread size	Connector
360081032002C	0 - 5 Bar (72 Psi)	M10x1	2 Screw terminals
360081032001C	0 - 5 Bar (72 Psi)	1/8"-27NPTF	2 Screw terminals

Note: For single terminals (earth return) or dual station senders, refer to pages 32 - 33

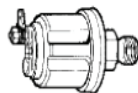

Temperature Sender Water

Part Number	Range	Thread size	Connector
323805001001K	40 - 120C (250F)	M14x1.5	2 spade terminals
323805001015N	40 - 120C (250F)	M18x1.5	2 spade terminals
323805001004K	40 - 120C (250F)	1/2"-14NPTF	2 spade terminals
323805001007N	40 - 120C (250F)	1/4"-18NPTF	2 spade terminals



Sender - Fuel

3 - 180 Ohms Fuel Level Sender (See pages 20 & 22)

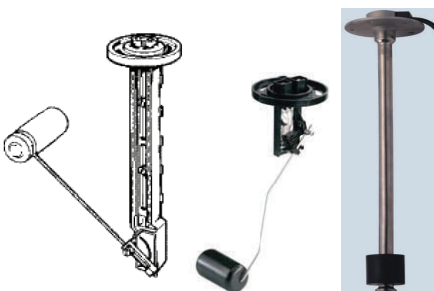

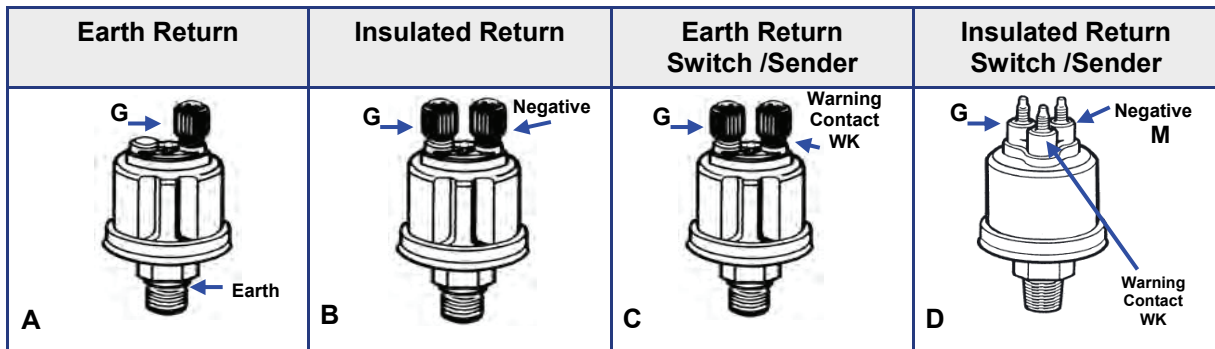

Pressure Sender - Oil / Air Single Station

Part Number	Range Bar (Psi)	Thread Size	Switch Point Bar (Psi)	Picture	Ohms Range
360081032025C	0 - 2 Bar (75)	1/8"-27NPTF	---	B	10 - 180
360081032011C	0 - 2 Bar (75)	M12x1.5	---	B	10 - 180

Pressure Sender - Oil / Air Single Station

Part Number	Range Bar (Psi)	Thread Size	Switch Point Bar (Psi)	Picture	Ohms Range
360.001	0 - 5 Bar (75)	1/8"-27NPTF	---	A	10 - 180
360.004	0 - 5 Bar (75)	1/4"-18NPTF	---	A	10 - 180
360.016	0 - 5 Bar (75)	1/8"-28BSP	---	A	10 - 180
360081032001C	0 - 5 Bar (75)	1/8"-27NPTF	---	B	10 - 180
360081032002C	0 - 5 Bar (75)	M10x1	---	B	10 - 180
360081030001K	0 - 5 Bar (75)	M10x1	0.25 Bar (3.5)	C	10 - 180
360081030002K	0 - 5 Bar (75)	M10x1	0.5 Bar (7)	C	10 - 180
360081030028K	0 - 5 Bar (75)	M14x1.5	0.5 Bar (7)	C	10 - 180
360081030049K	0 - 5 Bar (75)	1/8"-27NPTF	0.5 Bar (7)	C	10 - 180
360081030014C	0 - 5 Bar (75)	M10x1	0.6 bar (8.5)	C	10 - 180
360081030010C	0 - 5 Bar (75)	1/8"-27NPTF	1.4 Bar (11.5)	C	10 - 180
360081039002C	0 - 5 Bar (75)	1/8"-27NPTF	11.5 Psi	D	10 - 180
360081039004C	0 - 80 Psi	1/8"-27NPTF	10 Psi	D	10 - 180

Pressure Sender - Oil / Air Dual Station

Part Number	Range Bar (Psi)	Thread Size	Switch Point Bar (Psi)	Picture	Ohms Range
362081001001K	0 - 5 Bar (75)	1/8"-27NPTF	---	B	5 - 90
362081001002K	0 - 10 Bar (150)	1/8"-27NPTF	---	B	5 - 90
362081003002K	0 - 10 Bar (150)	1/8"-27NPTF	---	A	5 - 90
362081002001K	0 - 25 Bar (350)	1/8"-27NPTF	---	B	5 - 90
362081004001C	0 - 25 Bar (350)	1/8"-27NPTF	---	A	5 - 90

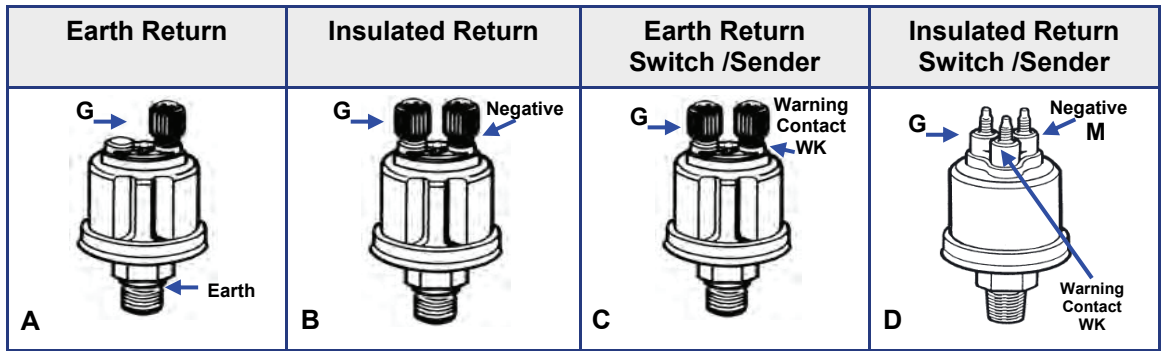

Pressure Sender/Switch - Oil / Air Single Station

Part Number	Range Bar (Psi)	Thread Size	Switch Point Bar (Psi)	Picture	Ohms Range
360081030009K	0 - 10 Bar (150)	M10x1	0.5 Bar (7)	C	10 - 184
360081030022C	0 - 10 Bar (150)	M12x1.5	0.5 Bar (7)	C	10 - 184
360081030052C	0 - 10 Bar (150)	1/8"-27NPTF	0.5 Bar (7)	C	10 - 184
360081030039C	0 - 10 Bar (150)	M10x1	0.75 Bar (10.7)	C	10 - 184
360081030015C	0 - 10 Bar (150)	1/8"-27NPTF	0.8 Bar (11.5)	C	10 - 184
360081030017C	0 - 10 Bar (150)	M10x1	0.9 Bar (12)	C	10 - 184
360081039003	0 - 10 Bar (150)	1/8"-27NPTF	0.8 Bar (11.5)	D	10 - 184

Pressure Sender - Oil / Air Single Station

360081038003C	0 - 25 Bar (400)	1/8"-27NPTF	-----	B	10 - 184
---------------	------------------	-------------	-------	---	----------

1-pole Common Ground
Screw M4 x 5



Insulated Return
Screw M4 x 5 (2x)



Insulated Return
6.3 x 0.8 mm riveted



Pressure Switches - Heavy Duty

Part Number	Switch Point Bar (Psi)	Thread Size	Terminals	Picture	Switch Contact
230112005006	0.5 Bar (7) Fixed	1/8"-27NPTF	Screw x 2 Insulated Return	B	N/C Falling Pressure
230.044	0.5 Bar (7) Fixed	1/8"-27NPTF	Screw x 2 Insulated Return	B	N/C Falling Pressure
230213002004	4.5 Bar (64) Fixed	M10 x 1	Screw x 2 Insulated Return	B	N/C Falling Pressure
230213002001	7.5 Bar (64) Fixed	1/8"-27NPTF	Screw x 2 Insulated Return	B	N/C Falling Pressure
230.041	0.7 Bar (10) Fixed	1/8"-27NPTF	Screw x 1 Earth Return	A	N/C Falling Pressure
230.701	1.05 Bar (15) Fixed	1/8"-27NPTF	Screw x 2 Insulated Return	B	N/C Falling Pressure
230.050	0.5 Bar (7) Fixed	1/8"-27NPTF	Screw x 2 Insulated Return	B	N/O Falling Pressure
230.990	7 - 25 Psi Adjustable	1/8"-27NPTF	Screw x 2 Insulated Return	C	N/C Falling Pressure
230.993	15 - 150 Psi Adjustable	1/8"-27NPTF	Screw x 2 Insulated Return	C	N/C Falling Pressure

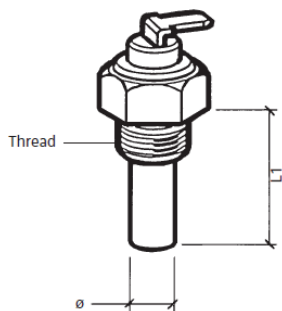

1-pole Common Ground
6.3 x 0.8 mm

A



1-pole Common Ground

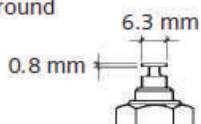

B

1-pole Common Ground
Hex nut



C

Insulated Return
6.3 x 0.8 mm (2x)



D

Blade connector
WK: 4.8 x 0.8 mm
G: 6.3 x 0.8 mm
WK = Warning Contact
G = Sensor

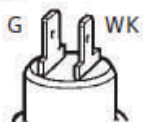

E

2 blade connectors arranged in the form of letter "T"
6.3 x 0.8 mm
WK = Warning Contact
G = Sensor

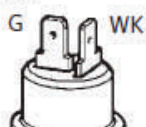

F

Temp Senders

40 -120 Deg C

Part Number	Switch Point	Thread Size	Term	Body Length	°C ▶ Ohms
323801001006K	-----	M14x1.5	A	29 mm	90 ▶ 51.2 ± 5.3
323801001040N	-----	M16x1.5	A	29 mm	90 ▶ 51.2 ± 5.3
323801001022K	-----	M18x1.5	A	29 mm	90 ▶ 51.2 ± 5.3
323801001010K	-----	1/2-14 NPTF	A	29 mm	90 ▶ 51.2 ± 5.3
323801001009N	-----	1/4-18 NPTF	A	29 mm	90 ▶ 51.2 ± 5.3
323801001007N	-----	3/8-18 NPTF	A	29 mm	90 ▶ 51.2 ± 5.3
323801001008N	-----	5/8-18 UNF-3A	A	29 mm	90 ▶ 51.2 ± 5.3
323805001001K	-----	M14x1.5	D	29 mm	90 ▶ 51.2 ± 5.3
323805001015N	-----	M18x1.5	D	29 mm	90 ▶ 51.2 ± 5.3
323805001004K	-----	1/2-14 NPTF	D	29 mm	90 ▶ 51.2 ± 5.3
323805001007N	-----	1/4-18 NPTF	D	29 mm	90 ▶ 51.2 ± 5.3
323805001005N	-----	3/8-18 NPTF	D	29 mm	90 ▶ 51.2 ± 5.3
323805001002C	-----	5/8-18 UNF-3A	D	29 mm	90 ▶ 51.2 ± 5.3

Dual Station Temp Senders

40 -120 Deg C

325805003001C	-----	1/4-18 NPTF	D	29 mm	90 ▶ 36.5 ± 2.7
325805003003C	-----	3/8-18 NPTF	D	29 mm	90 ▶ 36.5 ± 2.7

Temp Senders & Switch

40 -120 Deg C

323803001004D	90±3°C	M14x1.5	E	40 mm	90 ▶ 51.2 ± 5.3
323803001006D	96±3°C	M14x1.5	E	40 mm	90 ▶ 51.2 ± 5.3
323803001008D	110±3°C	M14x1.5	E	40 mm	90 ▶ 51.2 ± 5.3
323803001011D	95±3°C	5/8-18 NF-3	E	40 mm	90 ▶ 51.2 ± 5.3
323803001002D	98±3°C	5/8-18 NF-3	E	40 mm	90 ▶ 51.2 ± 5.3
323803001012D	100±3°C	5/8-18 NF-3	E	40 mm	90 ▶ 51.2 ± 5.3
323803001019D	95±3°C	1/2-14 NPTF	E	40 mm	90 ▶ 51.2 ± 5.3
323803001013D	106±3°C	M14x1.5	E	40 mm	90 ▶ 51.2 ± 5.3
323803004002D	105±3°C	M14x1.5	F	40 mm	90 ▶ 51.2 ± 5.3
323803001025	103±3°C	1/2-14 NPTF	E	40 mm	90 ▶ 51.2 ± 5.3

Temp Senders

50 -150 Deg C

Part Number		Thread Size	Term	Body Length	°C ▶ Ohms
323801010001D	-----	M10x1.5	D	29 mm	120 ▶ 36.5 ± 2.7
323805003001N	Dual gauge	M14x1.5	D	29 mm	90 ▶ 36.5 ± 2.7
323805003002N	Dual gauge	1/4-18 NPTF	D	29 mm	90 ▶ 36.5 ± 2.7

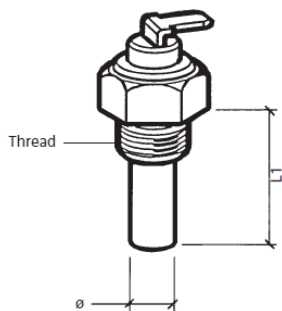

1-pole Common Ground
6.3 x 0.8 mm



1-pole Common Ground

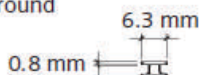

1-pole Common Ground
Hex nut

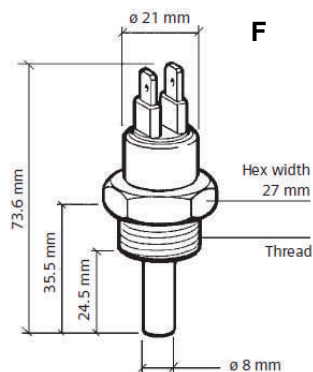
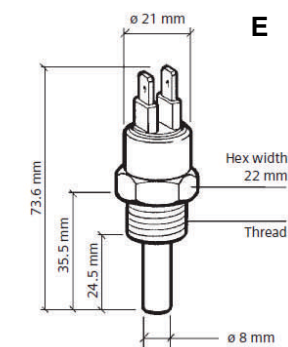
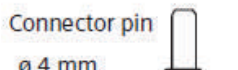

Temp Switch 3 Watts Normally Open Contact - Break 5° below Sw point

Part Number	Switch Point	Thread Size	Term	Body Length L	Max Temp	Ø mm
232011017148D	35±3°C	M14x1.5	A	29 mm	120	9.7
232011017087D	40±3°C	M14x1.5	D	29 mm	120	10
232011017038D	55±3°C	M14x1.5	A	29 mm	120	10
232011017017D	85±3°C	M14x1.5	A	29 mm	120	10
232011017016D	95±3°C	M14x1.5	A	29 mm	150	10
232011017080D	97±3°C	M14x1.5	A	29 mm	120	10
232011017099D	98±3°C	5/8-18 UNF-2A	A	29 mm	120	10
232011017034D	100±3°C	M14x1.5	A	29 mm	160	10
232011017131D	103±3°C	1/2-14 NPTF	A	29 mm	160	10
232011017010D	110±3°C	M14x1.5	A	29 mm	160	10
232011017032D	120±3°C	M14x1.5	A	29 mm	130	10
232011017103D	130±3°C	M14x1.5	A	29 mm	150	10
232011017004D	140±10°C	M14x1.5	A	29 mm	150	10
232011005027D	150±5°C	M10x1.5	B	38.5 mm	200	6.9
232011005004D	170±5°C	M10x1.5	C	38.5 mm	220	6.9
232011005030D	185±5°C	M10x1.5	C	38.5 mm	230	6.9
232011019003D	195±10°C	M10x1.5	C	38.5 mm	250	6.9

Temp Switch 100 Watts Normally Open Contact - Break 5° below Sw point

Part Number	Switch Point	Thread Size	Term	Body Length L	Max Temp	Ø mm
X10232001001	64±3°C	M14x1.5	E	35.5 mm	110	8
X10232001002	82±3°C	M18x1.5	E	35.5 mm	110	8
X10232001003	86±3°C	M18x1.5	E	35.5 mm	110	8
X10232001004	92±3°C	M18x1.5	E	35.5 mm	110	8
X10232001005	96±3°C	M18x1.5	E	35.5 mm	110	8
X10232001006	96±3°C	1/2-14 NPTF	E	43.5 mm	110	8
X10232001007	96±3°C	M14x1.5	E	35.5 mm	110	8
X10232001008	96±3°C	M22x1.5	F	35.5 mm	110	8
X10232001009	100±3°C	M18x1.5	E	35.5 mm	110	8
X10232001010	105±3°C	M18x1.5	E	35.5 mm	160	8

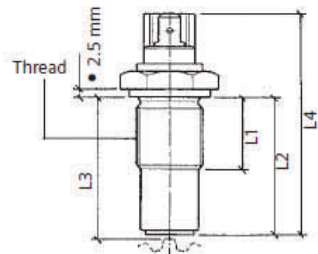
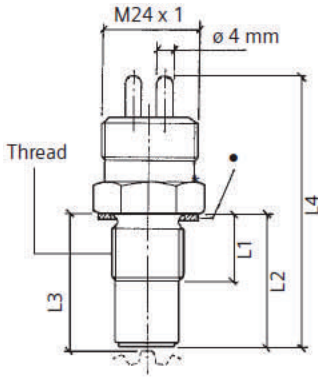

Blade connector 6.3 x 0.8 mm (2x)

Inductive

Part Number	Pic	Thread Size	L1 mm	L2 mm	L3 mm	L4 mm
340804007013C	B	M18 x 1,5	27	34	35.1 ± 0.1	62
340804007004C	B	3/4-16 UNF-2A	27.5	28.5	29.6 ± 0.1	70
340804007011C	B	M18 x 1,5	33	34	35.1 ± 0.1	70
340804007019C	B	M18 x 1,5	18.2	70.7	71.8 ± 0.1	79.7
340804005015C	A	M18x1,5	18	99.1	101.15–100.55	135.6

Hall Effect & AC Generator

Part Number	Voltage	Thread Size	Pic	Type	Imp/Rev	Plug Kit
K46020	12/24V	M22x1.5	1	H/E	8	K72221
K46021	12/24V	7/8"-18UNF	1	H/E	8	K72221
K70450	12V	M22x1.5 L/ H Female	2	H/E	8	K72222
K70451	12V	7/8"18UNF Female	2	H/E	8	K72222
340808001004G		7/8 – 18 NS -2A left hand	3	Gen	4	

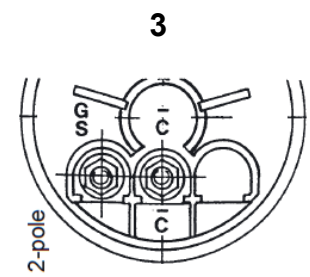
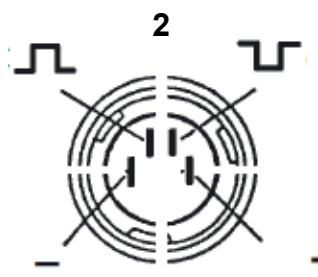
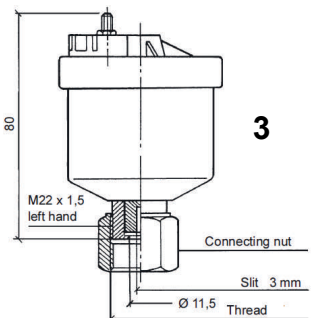
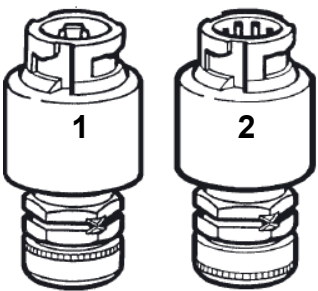



Lever Fuel Sensor - with low fuel alarm

Part Number	Ohms Range	Adjustable	Pitch Ø
A2C59510165	Empty = 3 - Full = 180	145 - 400 mm	54 mm
A2C59510166	Empty = 240 - Full = 33	145 - 400 mm	54 mm
A2C59510167	Empty = 5 - Full = 90	145 - 400 mm	54 mm

Lever Fuel Sensor - without low fuel alarm

Part Number	Adjustable 145 - 400 mm	Ohms Range	Pitch Ø
A2C59510171	Empty = 3 - Full = 180	145 - 400 mm	54 mm
A2C59510172	Empty = 240 - Full = 33	145 - 400 mm	54 mm
A2C59510173	Empty = 5 - Full = 90	145 - 400 mm	54 mm

An economical and practical solution for fuel monitoring for tank depths from 140mm to 400mm

Engineered with a redundant dual wiper system, our unique VDO 'quiet arm' and thick film technology, this new VDO fuel sender leads the field in reliability and durability.

In fact, this family of senders has the ability to withstand over one million swing arm cycles without failure. ALAS I senders feature our unique slotted SAE five-hole flange mount, an industry first that gives you the utmost in versatility for sender mounting positions. Three resistance values are available, 10-180 ohm, 240-33 ohm & 90-0 ohm. ALAS I senders are available with an optional low fuel warning contact circuit found in no other universal

1. Available with low fuel warning contact.
2. Redundant ground connection.
3. Unique SAE 5-hole slotted mounting plate allows for positioning sender for left or right hand applications.
4. Stainless steel float arm and pivot adjusts from 140mm to 400mm.
5. "No sink" solid float.
6. VDO thick film element with 39-step resolution.
7. Redundant dual wiper system.
8. 'Quiet arm' minimizes float movement.

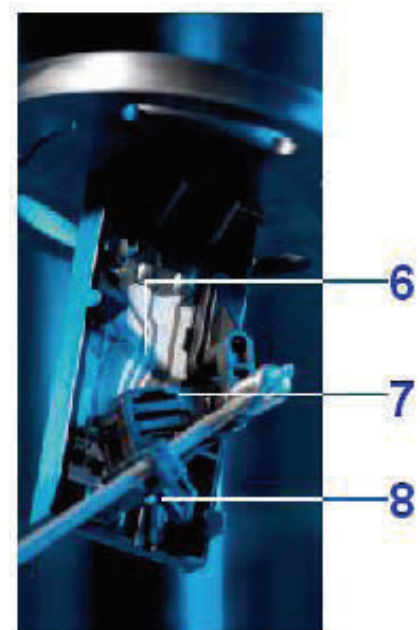

Fitting Instructions

Description	Page #
Sumlog - Compass - Wind Direction & Speed - Close Haul	38
Sumlog - Depth - Compass	39
Sumlog	40
Tachourmeter	41
Tachometer	42
Synchroniser	43
Rudder Angle Gauge	44
Fuel Level Gauge & Sender Arm / Reed Switch Type	45
Fuel Level Gauge & Sender Tubular Type	46
Fresh Water Level Gauge & Sender Reed Switch Type	47
Waste/Grey Water Gauge & Sender 4 - 20 mA Capacitance	48
Temp Gauge & Sender 40 - 120C / 50 - 150C	49
Outside Temp	50
Pyrometer 100 - 900°C	51
Pressure Gauge & Sender 5 Bar - 10 Bar	52
Pressure Gauge & Sender 25 Bar - 30 Bar	53
Ammeter External Shunt Hall Effect type	54
Ammeter External Shunt (Resistive)	55
Clock	56
Hourmeter	56
Alarm Switch Temp - Pressure - Fuel	57

Sumlog - Wind - Close Haul



Electrical diagram

Sumlog



Wind



Close Haul



AirmarSensor
p/n X12719000129

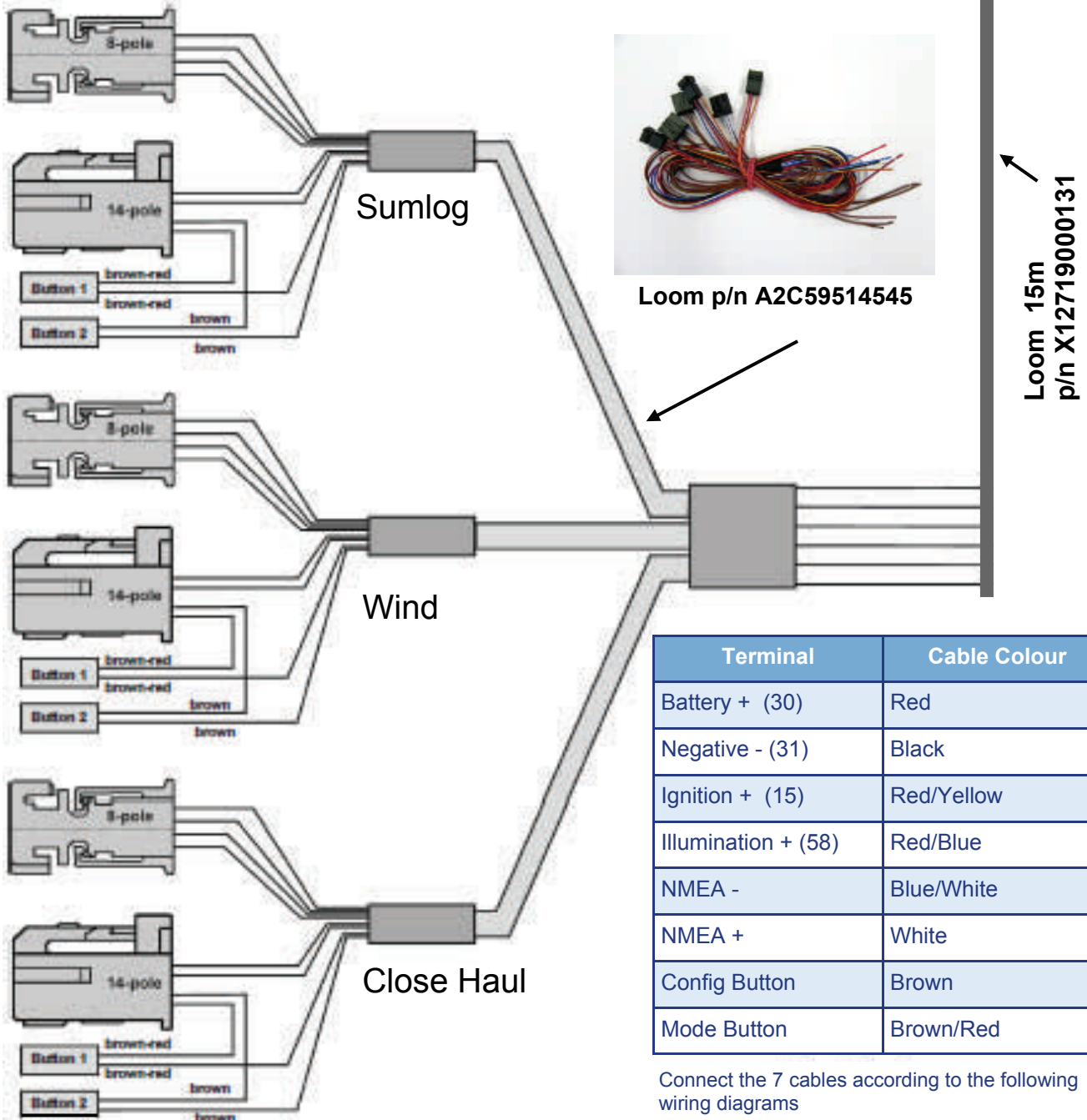

Loom p/n A2C59514545

Loom 15m
p/n X12719000131

Terminal	Cable Colour
Battery + (30)	Red
Negative - (31)	Black
Ignition + (15)	Red/Yellow
Illumination + (58)	Red/Blue
NMEA -	Blue/White
NMEA +	White
Config Button	Brown
Mode Button	Brown/Red

Connect the 7 cables according to the following wiring diagrams

Insert the plug into the gauge. Note the inverse polarity protection nose in the process.

Sumlog - Depth



Electrical diagram

Sumlog

Depth



Terminal	Cable Colour
Battery + (30)	Red
Negative - (31)	Black
Ignition + (15)	Red/Yellow
Illumination + (58)	Red/Blue
NMEA -	Blue/White
NMEA +	White
Config Button	Brown
Mode Button	Brown/Red

Connect the 7 cables according to the following wiring diagrams

Insert the plug into the gauge. Note the inverse polarity protection nose in the process.

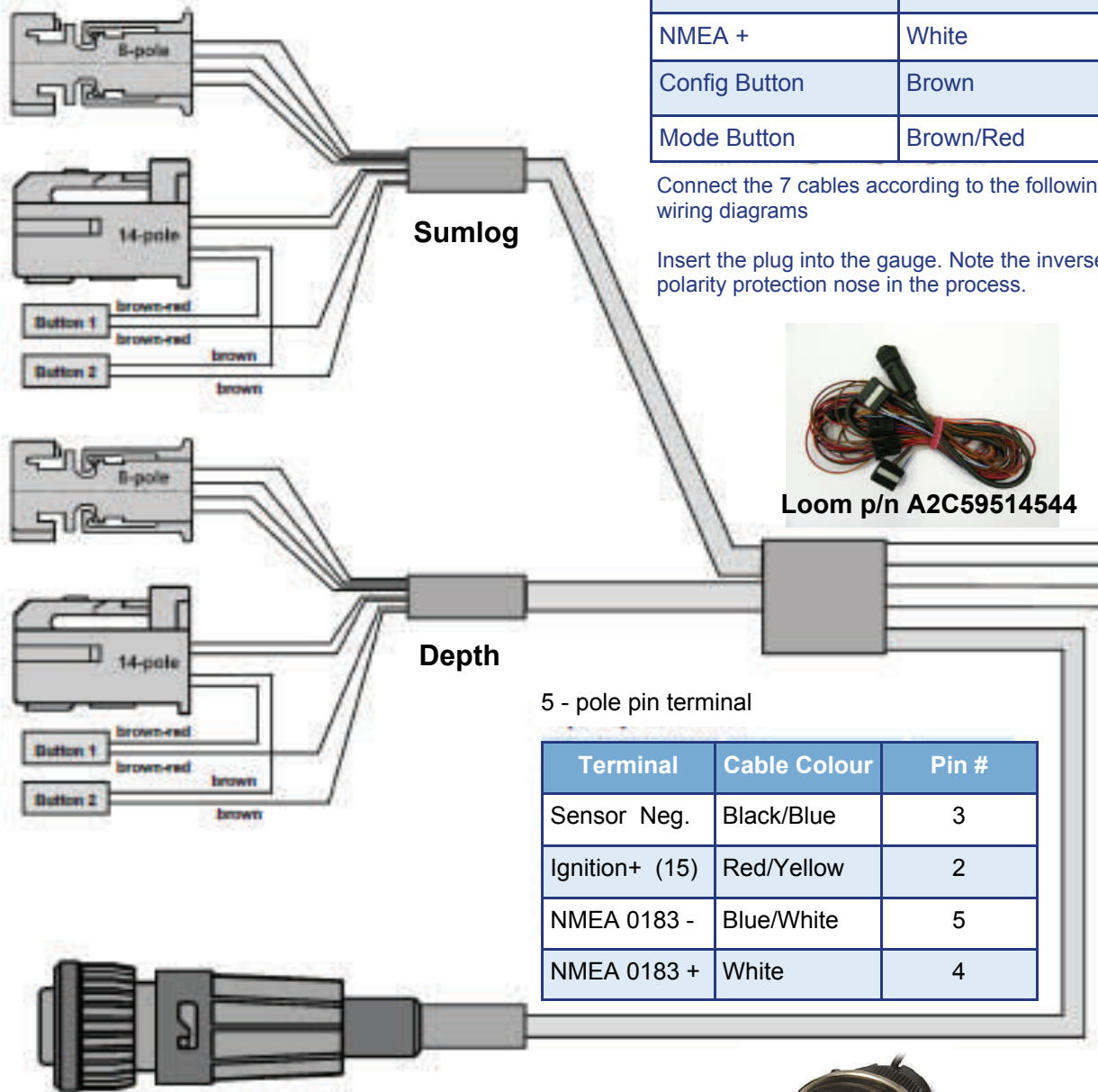

Loom p/n A2C59514544

5 - pole pin terminal

Terminal	Cable Colour	Pin #
Sensor Neg.	Black/Blue	3
Ignition+ (15)	Red/Yellow	2
NMEA 0183 -	Blue/White	5
NMEA 0183 +	White	4

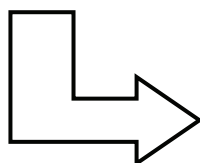

NMEA0183 Through-Hull Sensor for Water Temp, Speed, Depth



Sumlog electrical diagram

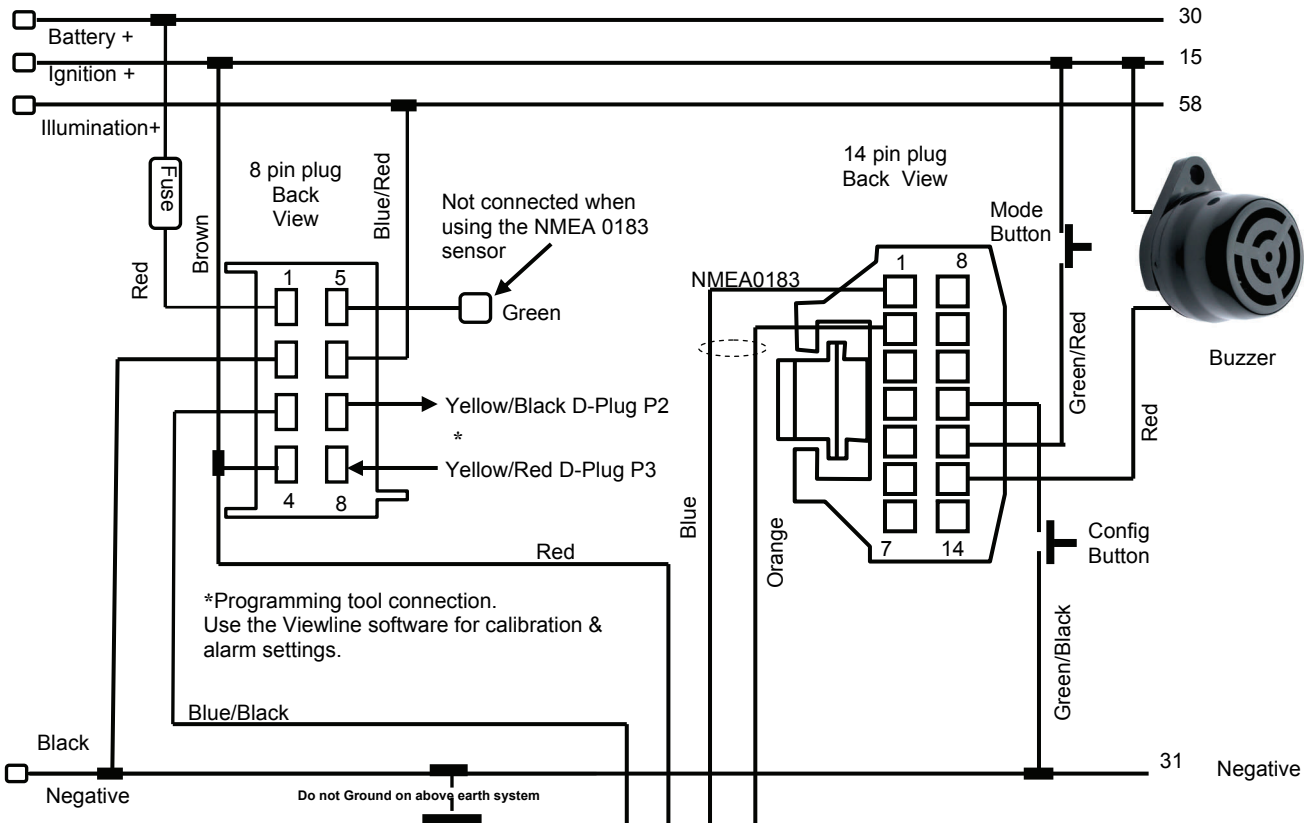

A2C59513503 Sensor to Sumlog, Loom
(only for sensors p/n X1171900058 or p/n X1171900053)



8 way connector Kit p/n A2C59510850

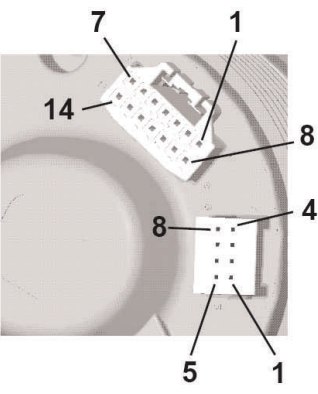

Connector Kit 14-pin - p/n A2C59510851



Airmar Sensors
p/n X11719000058 Tru-Hull
p/n X11719000053 Transom

NMEA0183 Sensors *



Through-Hull Kit

or

Transom Kit

See page 74 for calibration procedures

Note: * Set input calibration to NMEA0183 (No pulse calibration needed)
** Terminal 5 used only for Hall Effect Output Sensors

Tachourmeter electrical diagram

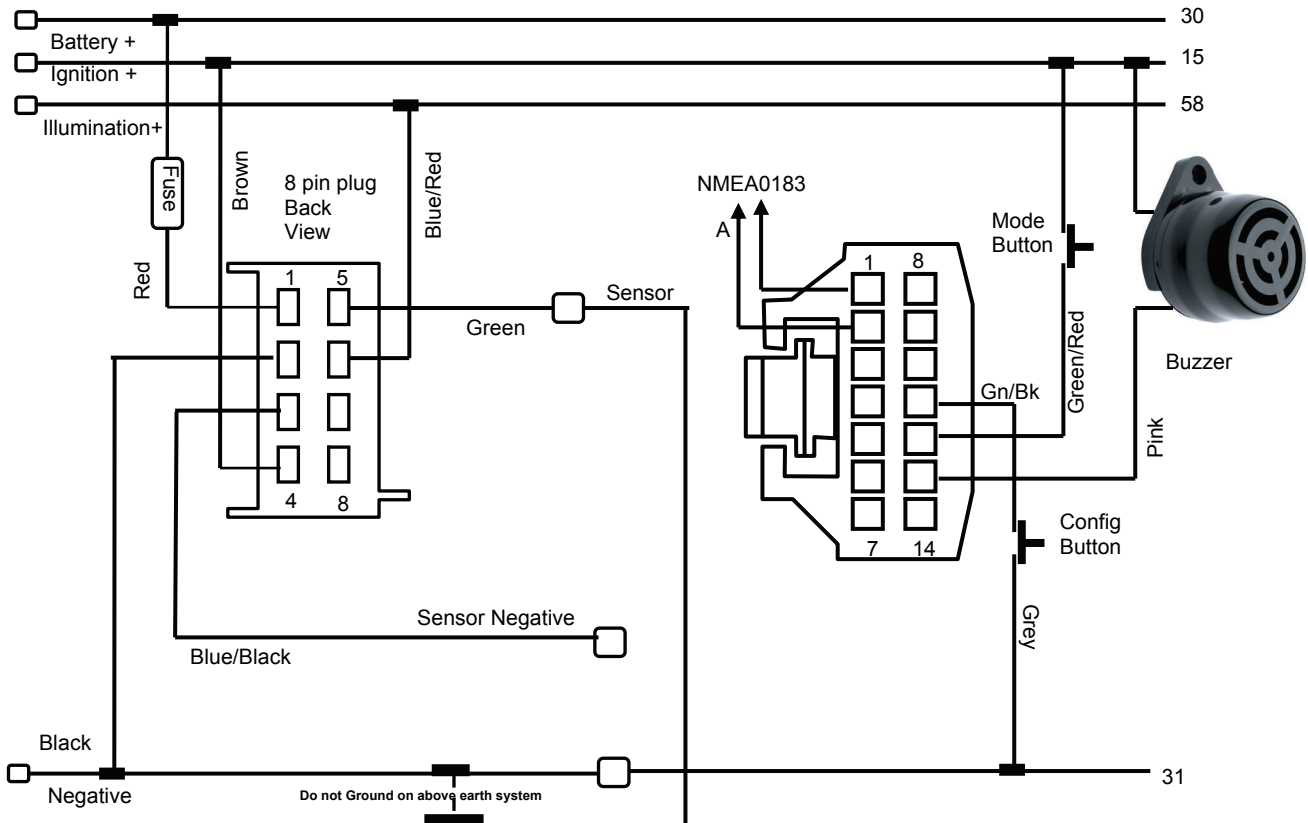

8 way connector Kit
p/n A2C59510850

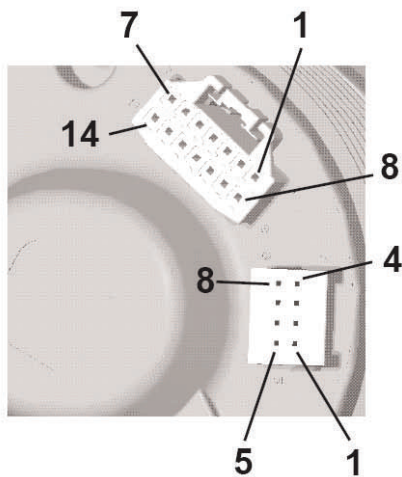

Connector Kit 14-pin -
p/n A2C59510851

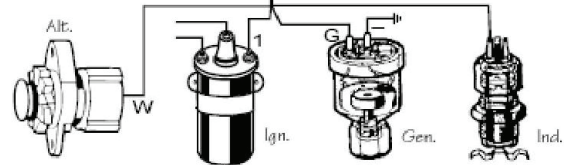

See page 81 for calibration procedures

Tachometer electrical diagram

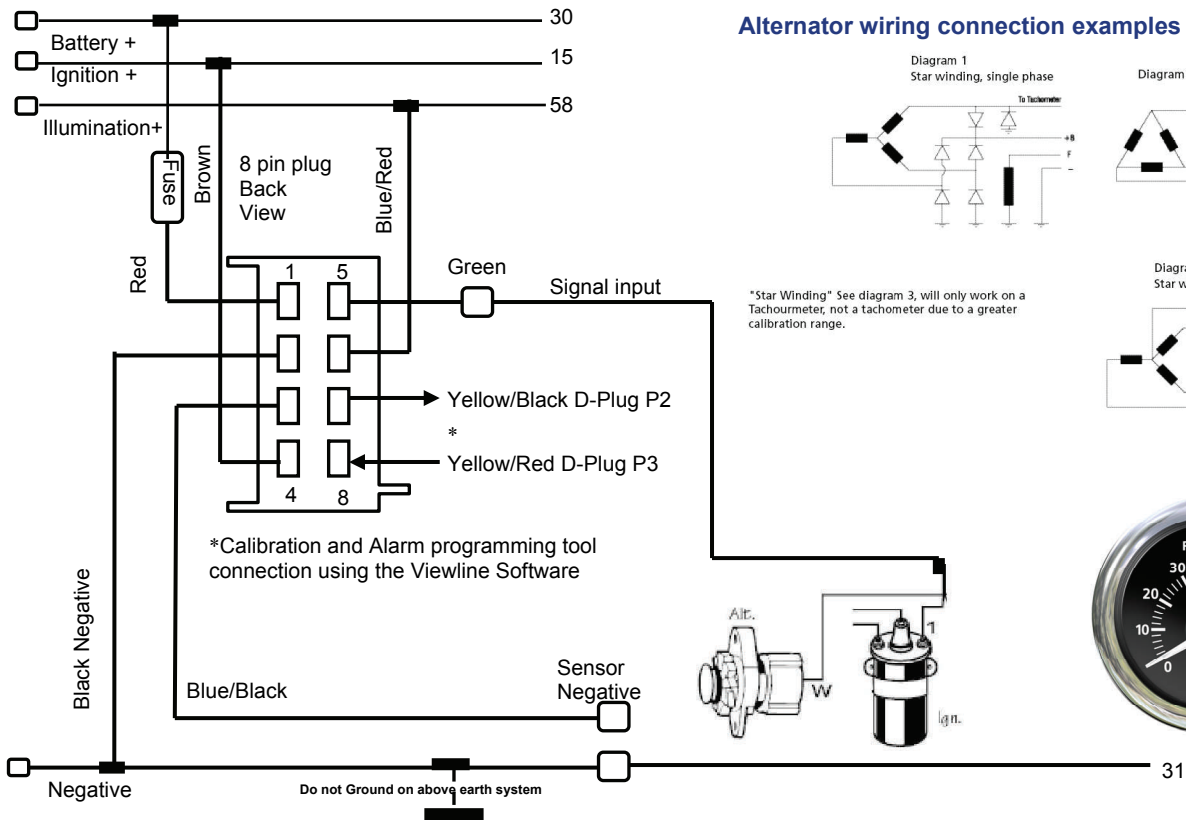

Alternator wiring connection examples

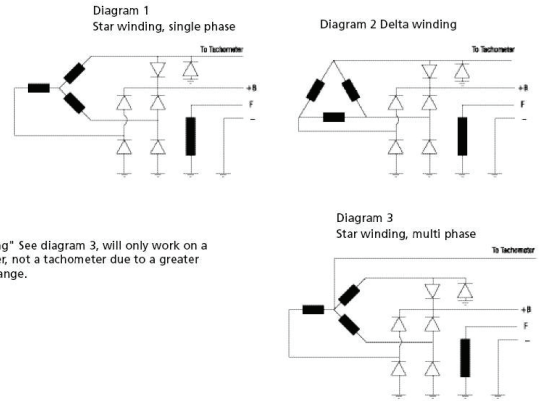

The tachometer can only be calibrated using the VDO Viewline Software p/n A2C50515259 & p/n 111.000 plus an Agreement issued by a VDO Partner (in each State), must be signed.

For software enquiry, contact Continental Pty Ltd, Customer Service 03 94681151.

Note: Tachometer will not operate off a Magneto signal.

Synchroniser Gauge Ø 85 mm

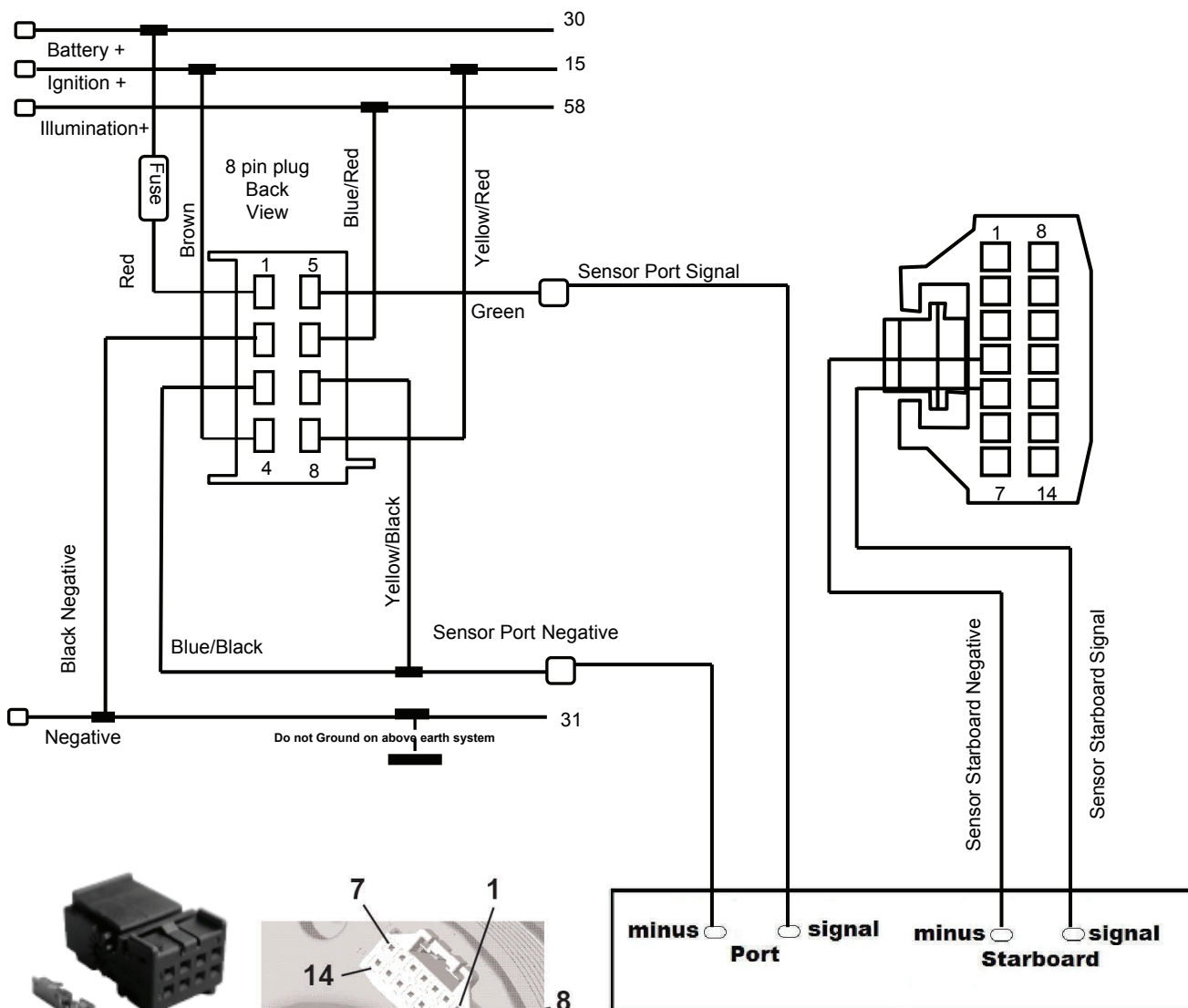

8 way connector Kit
p/n A2C59510850

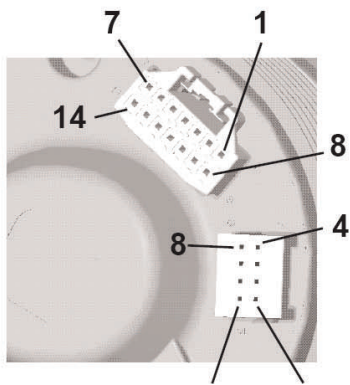

Connector Kit 14-pin -
p/n A2C59510851

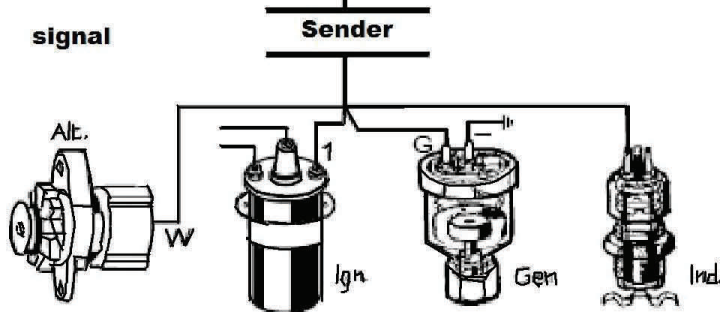

Rudder Angle



Rudder Angle Ø 52 mm & Ø 85 mm 12/24V

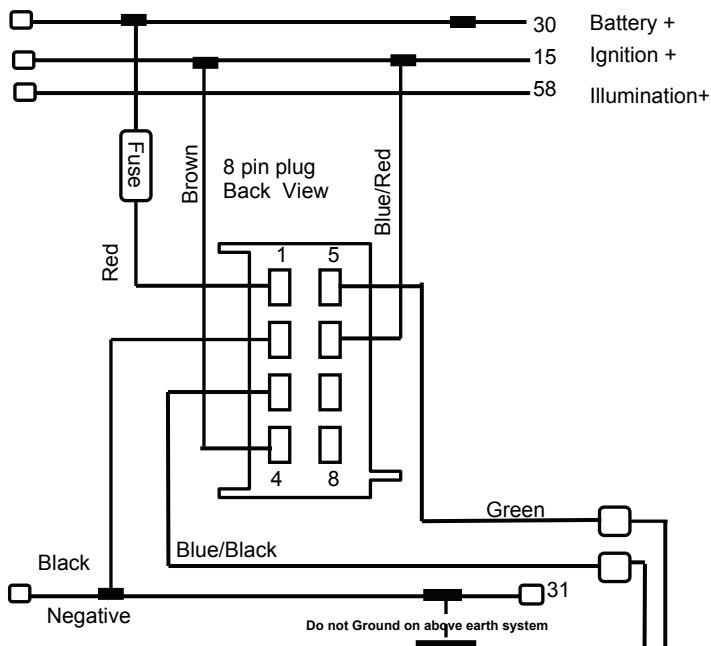

Note: For dual station installation, connect Green wire to second gauge

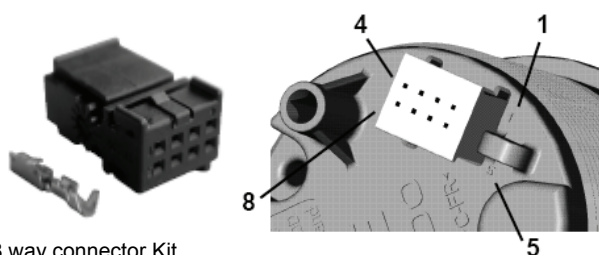

8 way connector Kit
p/n A2C59510850

Rudder Angle
Sender

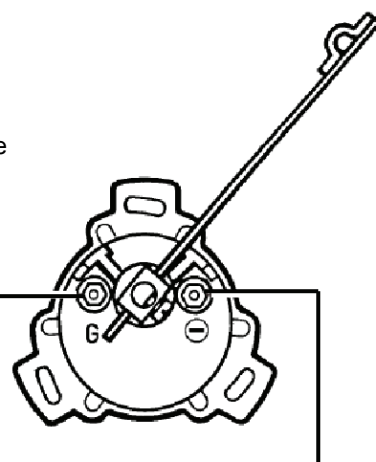

Rudder Angle sensor calibration

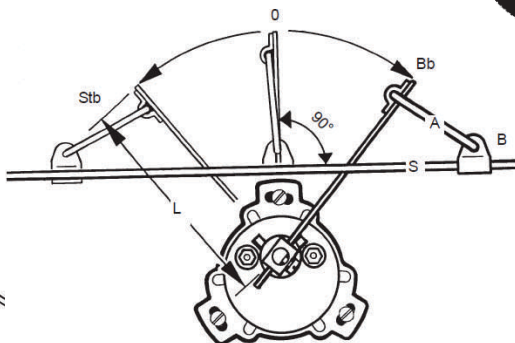
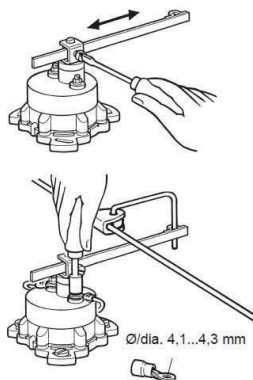

Bb

0

Stb

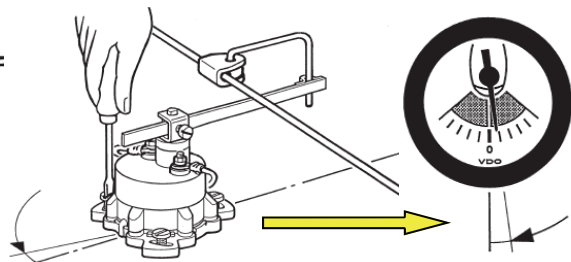

Fuel Gauge – Arm & Reed Switch Type Senders

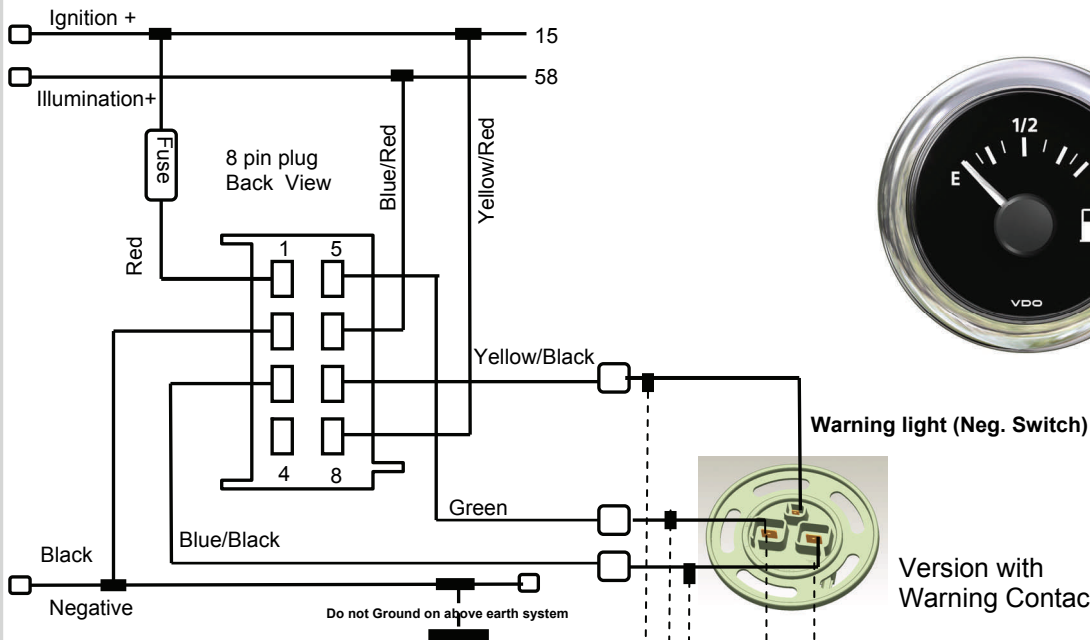

Warning light (Neg. Switch)

Version with Warning Contact

Arm type sender

Version without Warning Contact



8 way connector Kit
p/n A2C59510850

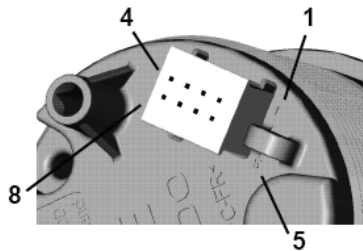

Reed Switch sender

0 to 1/1



Pin 1 - Wh - Low Fuel Warning
Pin 2 - Bl - Output signal
Pin 3 - Bk - Negative

Indication	0	1/4	1/2	3/4	1/1
Resistance (Ω)	3	45	85	138	180
Deflection ($^\circ \angle$)	0	17.2	41.2	73.8	88.8
Tolerance ($^\circ \angle$)	+ 3.6 - 3.6	\pm 3.6	\pm 3.6	\pm 3.6	+ 3.6 - 3.6

Fuel Gauge – Tubular Type Senders

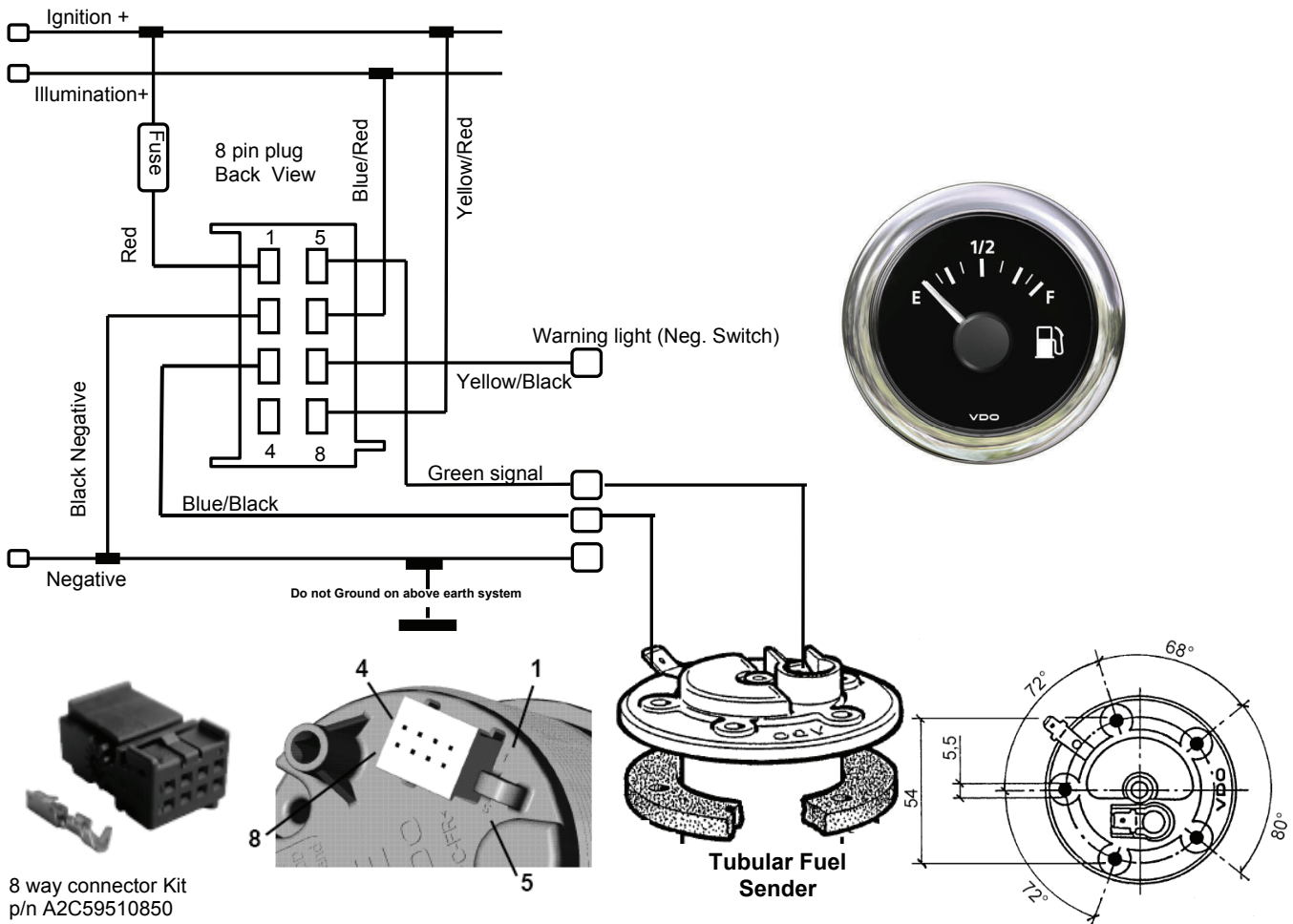

Sender Part No.	Length	Pitch Ø	Cut-out	Ohm Full	Ohms Empty
224011000015G	150mm	54mm	41mm	4.5	69
224011000016G	160mm	54mm	41mm	4.5	74
224011000017G	170mm	54mm	41mm	4.5	79.5
224011000018G	180mm	54mm	41mm	3	64
224011000019G	190mm	54mm	41mm	3	68
224011000020G	200mm	54mm	41mm	3	68
224011000021G	210mm	54mm	41mm	3	76
224011000022G	220mm	54mm	41mm	3	80
224011000023G	230mm	54mm	41mm	3	84
224011000024G	240mm	54mm	41mm	3	65.5
224011000025G	250mm	54mm	41mm	2.5	72
224011000026G	260mm	54mm	41mm	2.5	72
224011000027G	270mm	54mm	41mm	2.5	74.5
224011000028G	280mm	54mm	41mm	2.5	75.5
224011000029G	290mm	54mm	41mm	2.5	78
224011000030G	300mm	54mm	41mm	2.5	82.8

Sender Part No.	Length	Pitch Ø	Cut-out	Ohm Full	Ohms Empty
224011000031G	310mm	54mm	41mm	2.5	84
224011000032G	320mm	54mm	41mm	2.5	69.5
224011000033G	330mm	54mm	41mm	2.5	72
224011000034G	340mm	54mm	41mm	2.5	74
224011000035G	350mm	54mm	41mm	2.5	79.6
224011000036G	360mm	54mm	41mm	2.5	69
224011000037G	370mm	54mm	41mm	2.5	71
224011000038G	380mm	54mm	41mm	2.5	73
224011000039G	390mm	54mm	41mm	2.5	75
224011000040G	400mm	54mm	41mm	2.5	74.9
224011000045G	450mm	54mm	41mm	2.5	84.3
224011000050G	500mm	54mm	41mm	2.5	75.4
224011000055G	550mm	54mm	41mm	2.5	77.6
224011000060G	600mm	54mm	41mm	2.5	85.3
224011000065G	650mm	54mm	41mm	2.5	82.2
224011000070G	700mm	54mm	41mm	2	81.6
224011000075G	750mm	54mm	41mm	2	82
224011000080G	800mm	54mm	41mm	2	68.5

Fresh Water Gauge – Reed Switch Senders

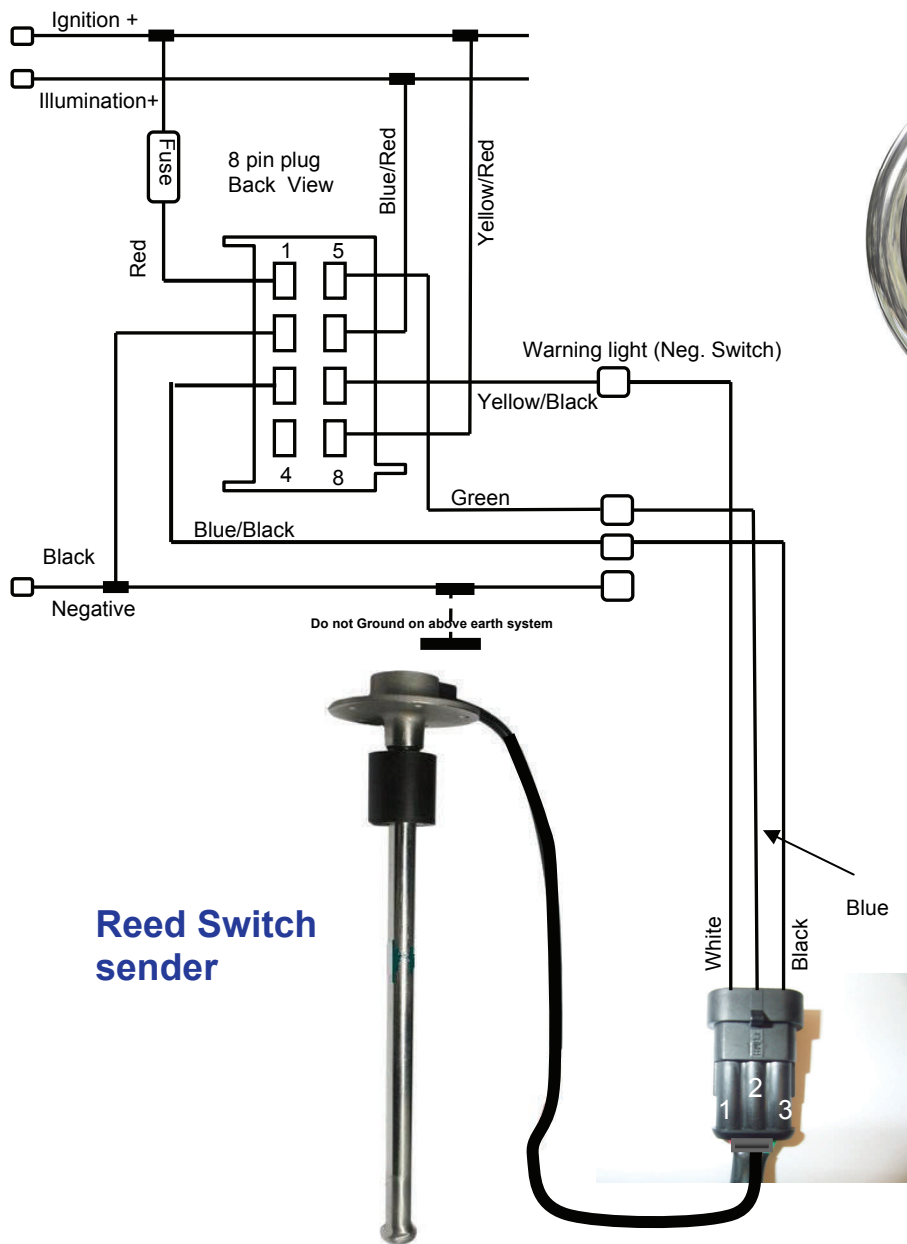

- Pin 1 - Wh - Low Water Warning
- Pin 2 - Bl - Output signal
- Pin 3 - Bk - Negative

Waste Water Gauge

Connected to a 4 - 20 mA Sender

Dual Station: Two Gauges off one sensor, parallel the second gauge wires

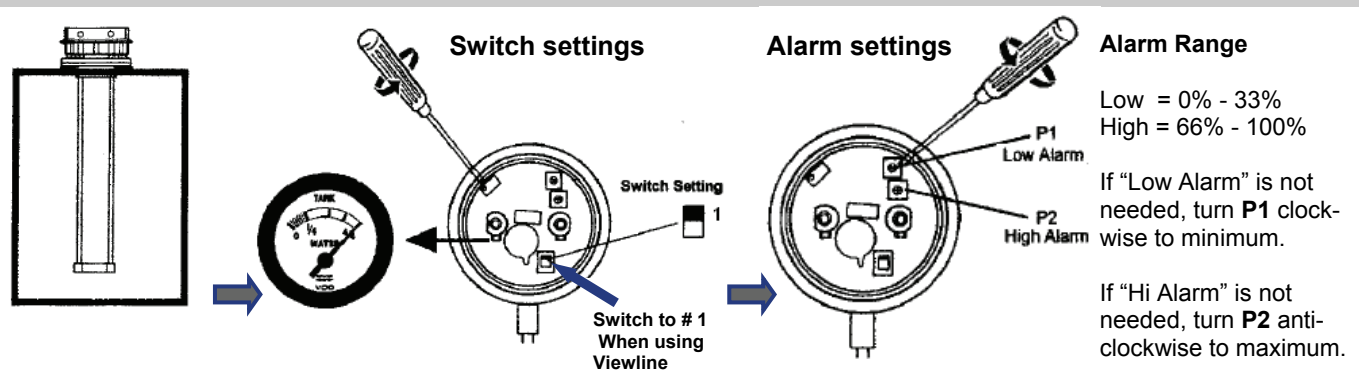
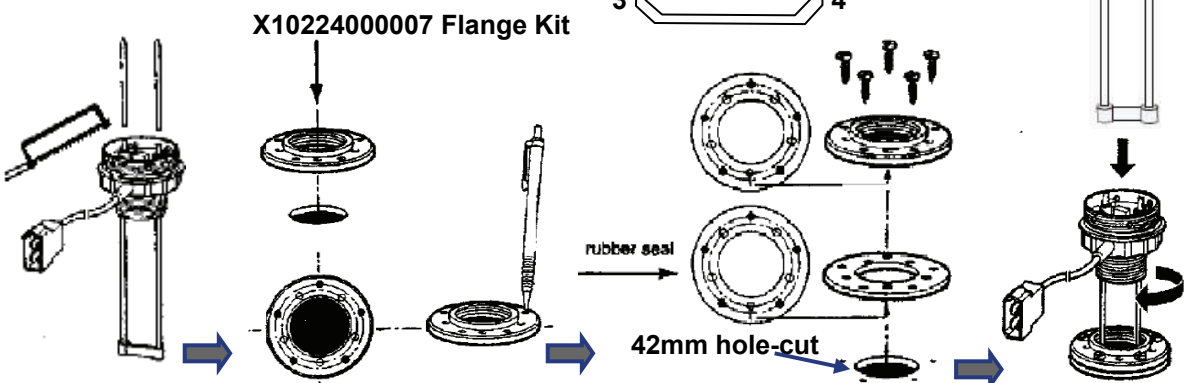
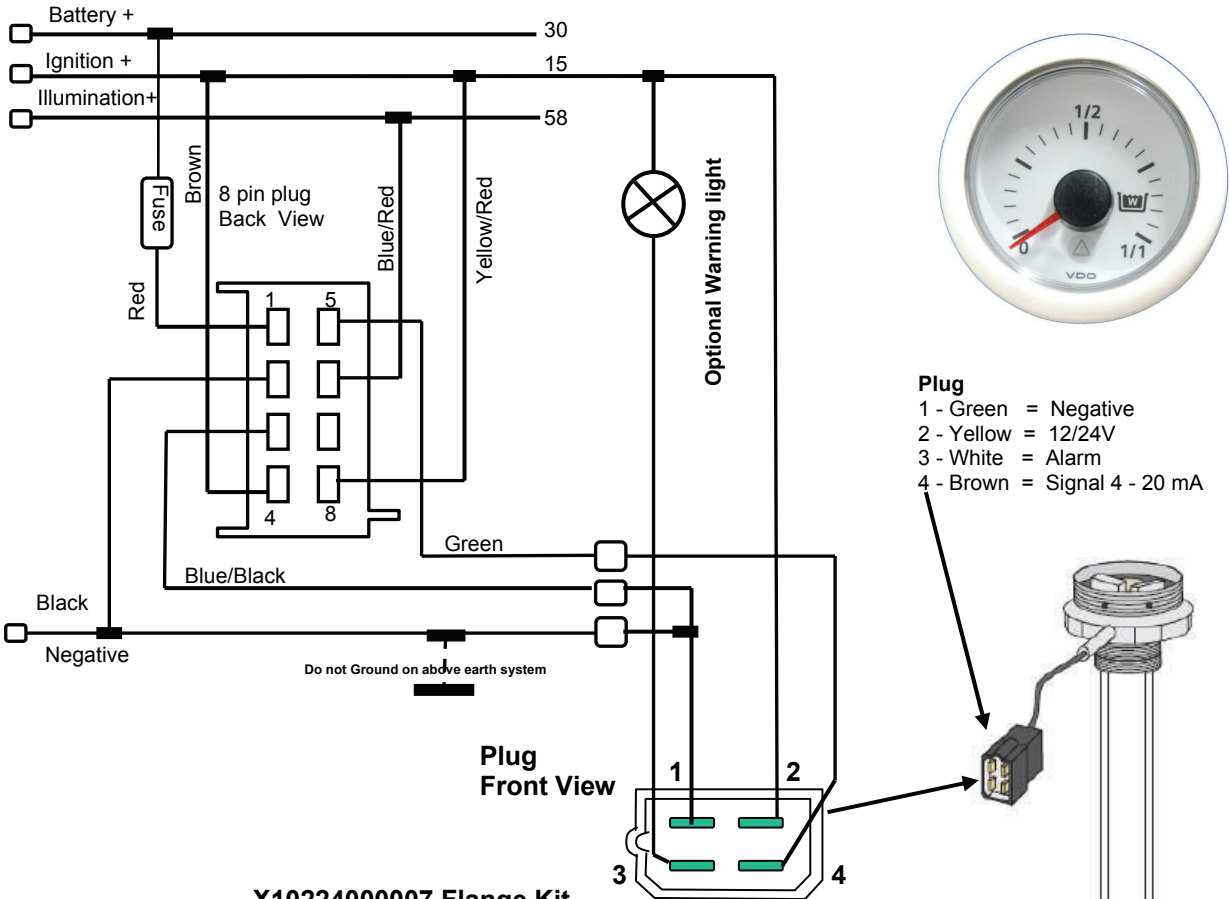

Temp Gauges 120° C and 150° C

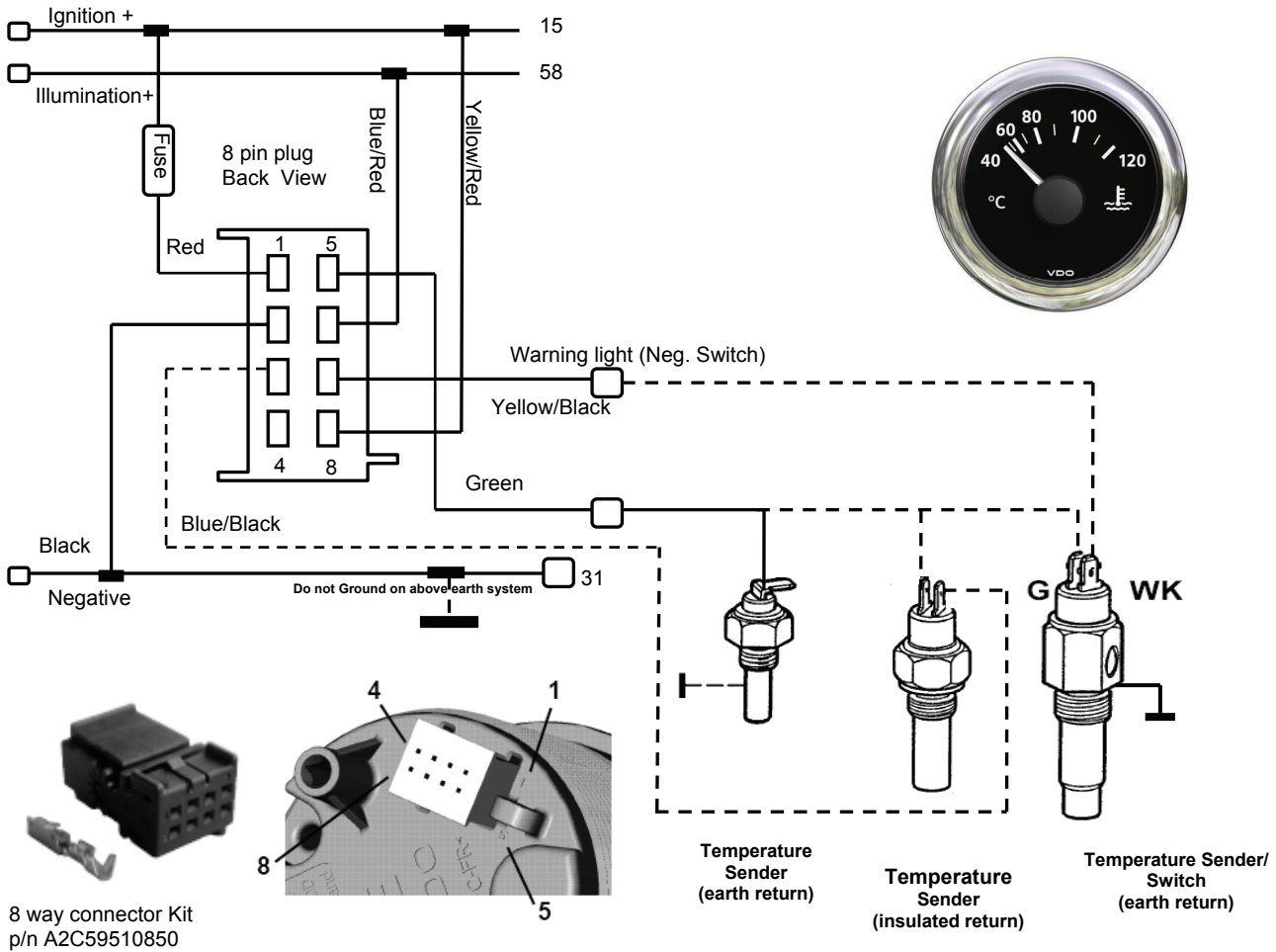

40 to 120 °C

Indication (°C)	40	50	60	70	80	90	100	110	120
Resistance (Ω)	287.4	193.3	134	95.2	69.1	51.3	38.6	29.4	22.7
Deflection (°∠)	0	3.3	8.3	15.5	25.8	40	58	75.2	88.2
Tolerance (°∠)	± 3.6	± 3.6	± 3.6	± 3.6	± 3.6	± 3.6	± 3.6	± 3.6	± 3.6

50 to 150 °C

Indication (°C)	50	80	90	100	110	120	130	140	150
Resistance (Ω)	322.8	112.5	83	62.2	47.5	36.5	28.9	23.1	18.6
Deflection (°∠)	0	12.4	19.8	29.6	42	56.8	69.7	80.2	88.1
Tolerance (°∠)	± 3.6	± 3.6	± 3.6	± 3.6	± 3.6	± 3.6	± 3.6	± 3.6	± 3.6

Temp Gauge -25° C to +50° C (Outside)

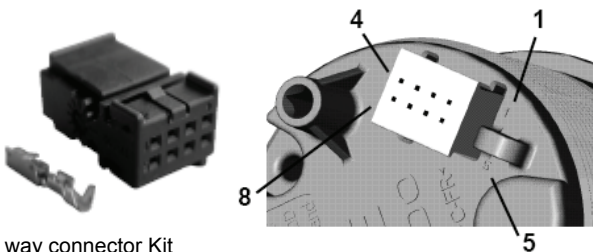
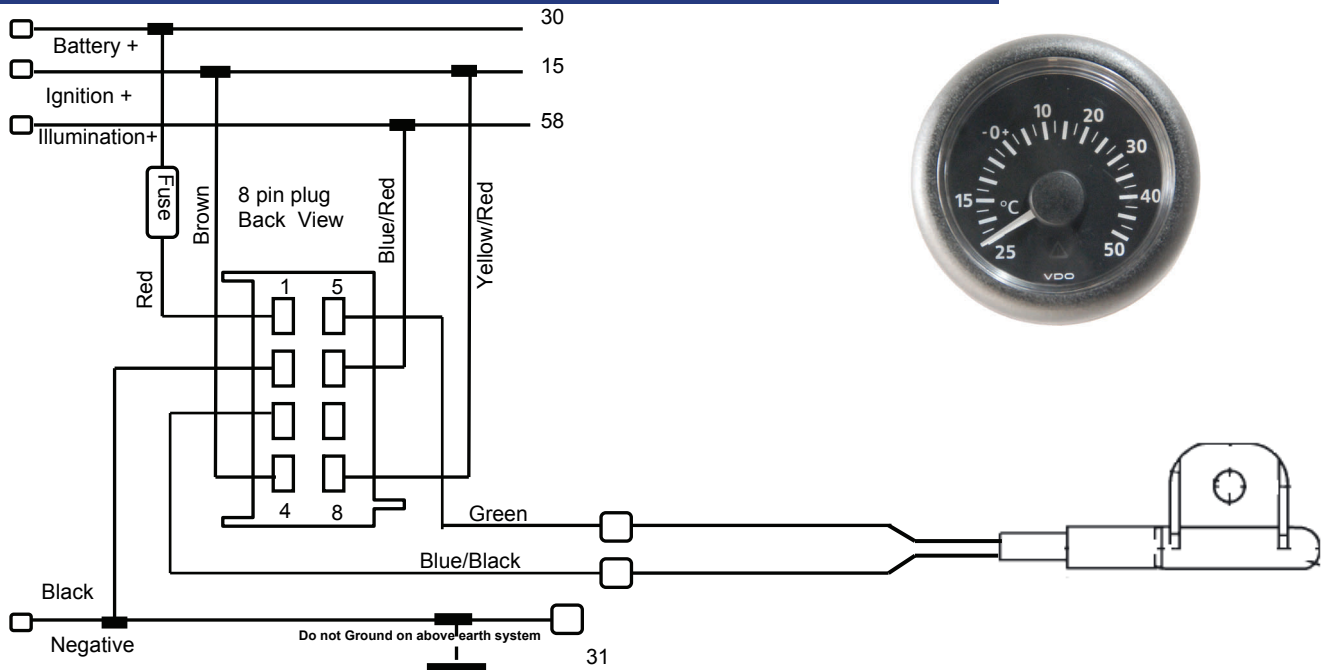

8 way connector Kit
p/n A2C59510850

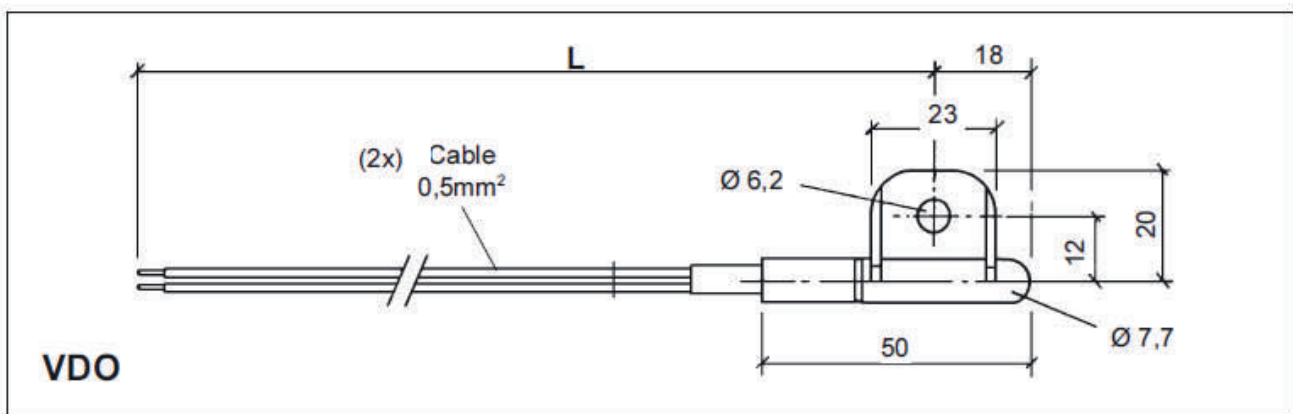

Temperature Sensors for Air Temperature p/n 323809010005C L = 3000 mm

Technical Data:

Version: Thermistor, insulated return

Independent voltage

Operating temperature:

- 40°C to + 85°C max.

Temperature response time: 3 minutes minimum after switching on operating current

Operational value: 0 DegC = 4082 Ohms ± 26 Ohms

Temperature



Pyrometer 100°C - 900°C

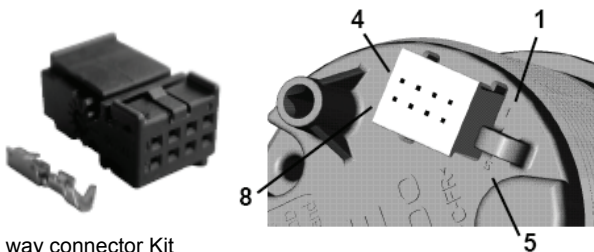
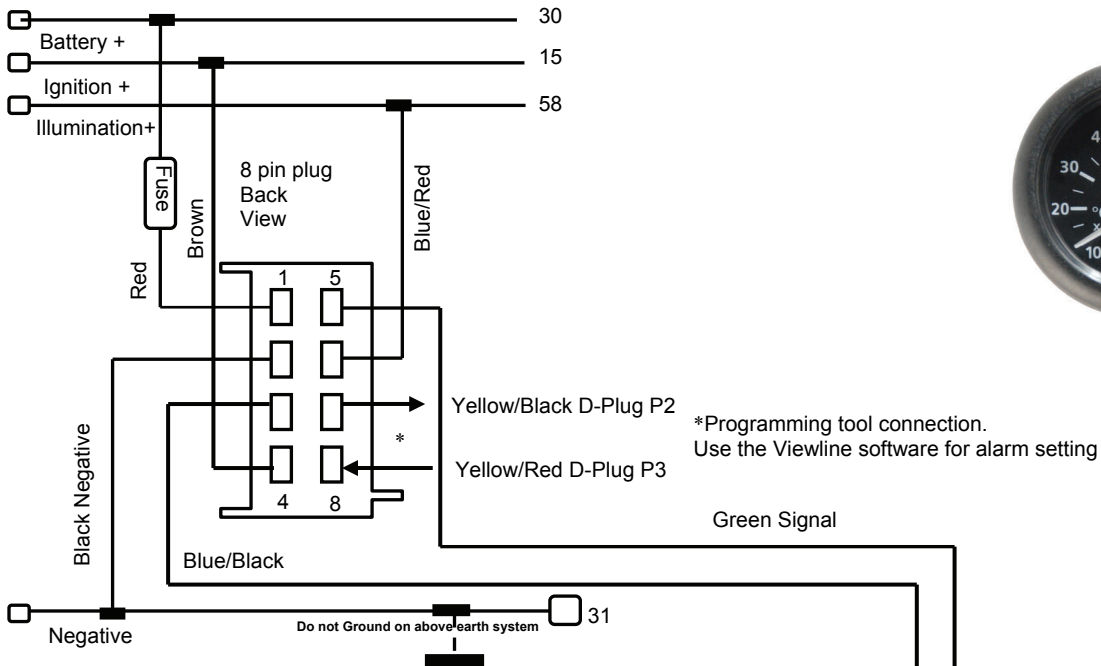

8 way connector Kit
p/n A2C59510850

Thermocouple Sender

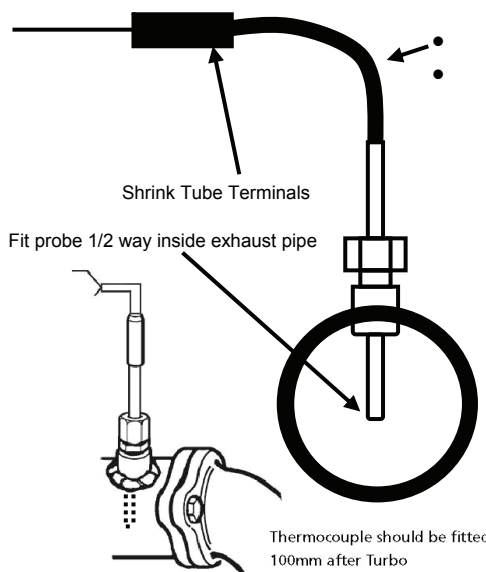

Deg °	Probe mV
100	4.04
200	8.137
300	12.20
400	16.4
500	20.64
600	24.902
700	29.128
800	33.277
900	37.325

Pressure Gauges 2, 5, 7, 10 Bar

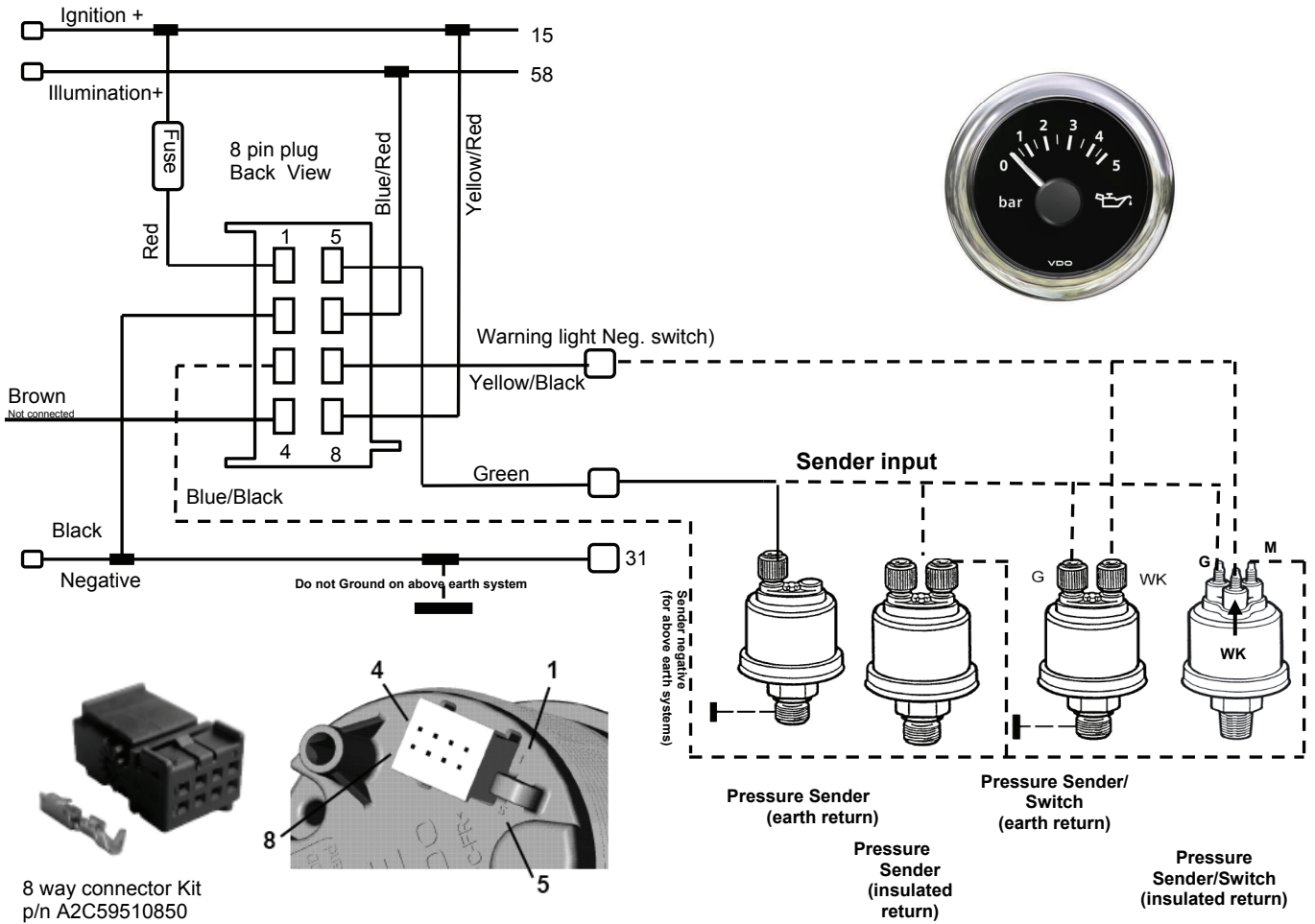

Calibration Chart

2 Bar

Bar (x100Kpa)	0	1	2
Resistance	10	99	184

5 Bar

Bar (x100Kpa)	0	0.5	1	1.5	2	2.5	3	3.5	4	4.5	5
Resistance	10	30	48	65	82	99	116	134	151	168	184

10 Bar

Bar (x100Kpa)	0	1	2	3	4	5	6	7	8	9	10
Resistance	10	31	52	71	88	106	124	140	155	170	184

Pressure Gauges 25, 30 Bar

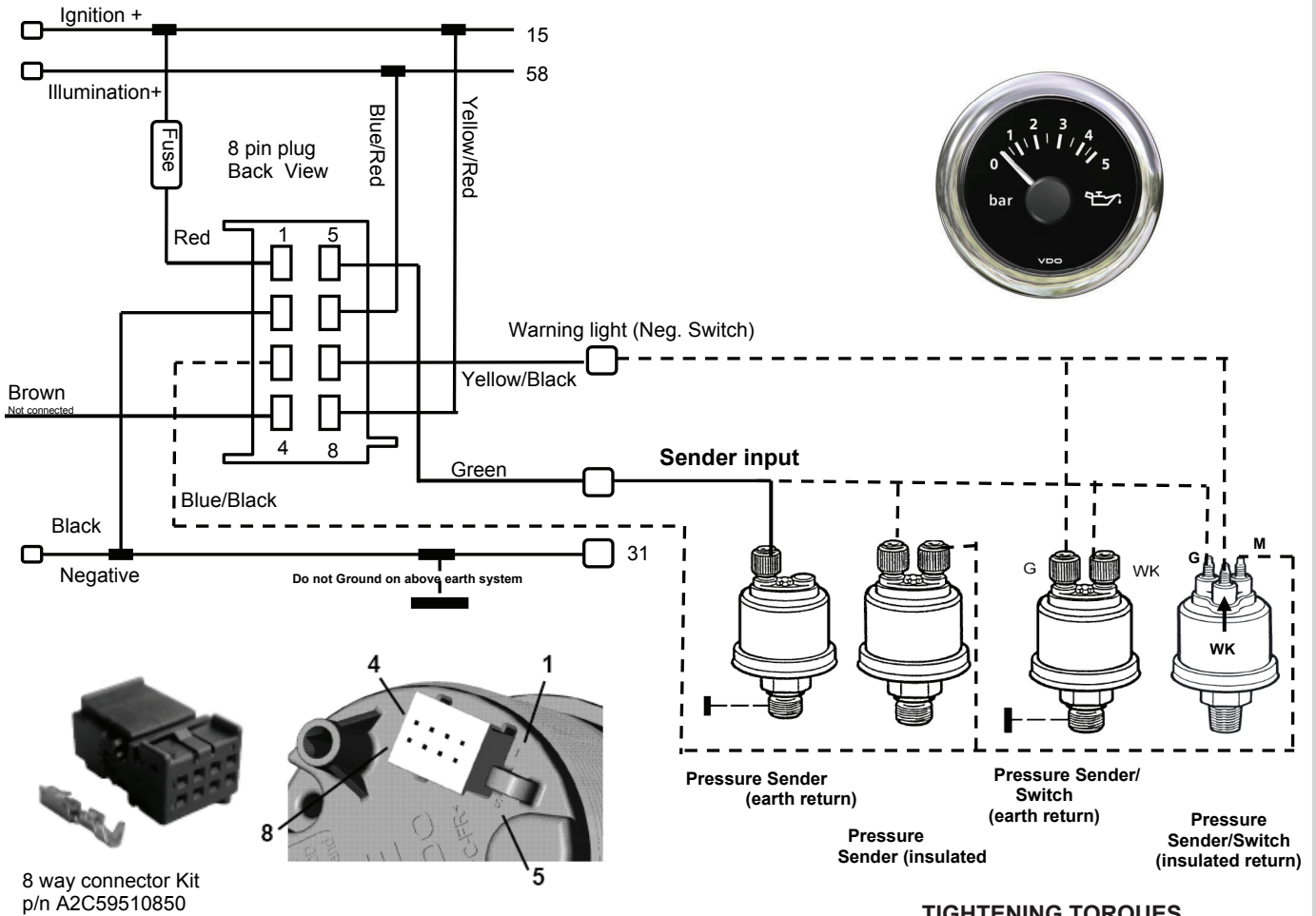

TIGHTENING TORQUES

- M10 x 1.0 10 Nm
- 1/8 – 27 NPTF 10 Nm
- M12 x 1.5 15 Nm
- 01.02.2020 15 Nm
- M14 x 1.25 20 Nm
- M14 x 1.5 20 Nm
- 1/4 – 18 NPTF 20 Nm
- 1/2 in. – 20 Whit. S 20 Nm
- 5/8 – 18 UNF-3A 20 Nm
- M16 x 1.5 30 Nm
- M18 x 1.5 30 Nm
- M20 x 1.5 30 Nm
- M22 x 1.5 30 Nm
- M24 x 1.5 30 Nm
- M26 x 1.5 30 Nm
- 3/8 – 18 NPTF 30 Nm
- 3/8 – 18 Dryseal NPTF 30 Nm
- 1/2 – 14 NPTF 30 Nm
- 3/4 – 16 UNF-3A 30 Nm
- R 3/8 30 Nm
- R 1/2 30 Nm

Note:

- Dual station senders have 1/2 of resistance range, Eg: 25 Bar is 92 Ohms
- For 0 to 30 Bar range application use a 0 to 25 Bar sender.

25 Bar (30 Bar)

Bar (x100Kpa)	0	2.5	5	7.5	10	12.5	15	17.5	20	22.5	25
Resistance	10	32	53	73	92	109	125	143	155	169	184

Ammeter External Shunt



Ammeter Gauges 30, 60, 100 & 150 AMPS

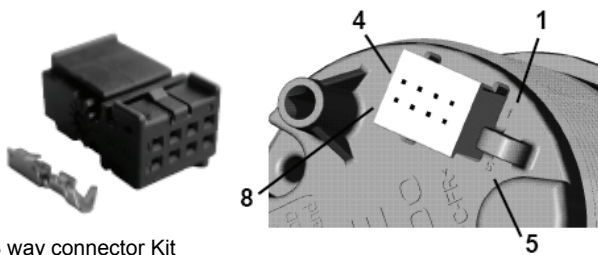
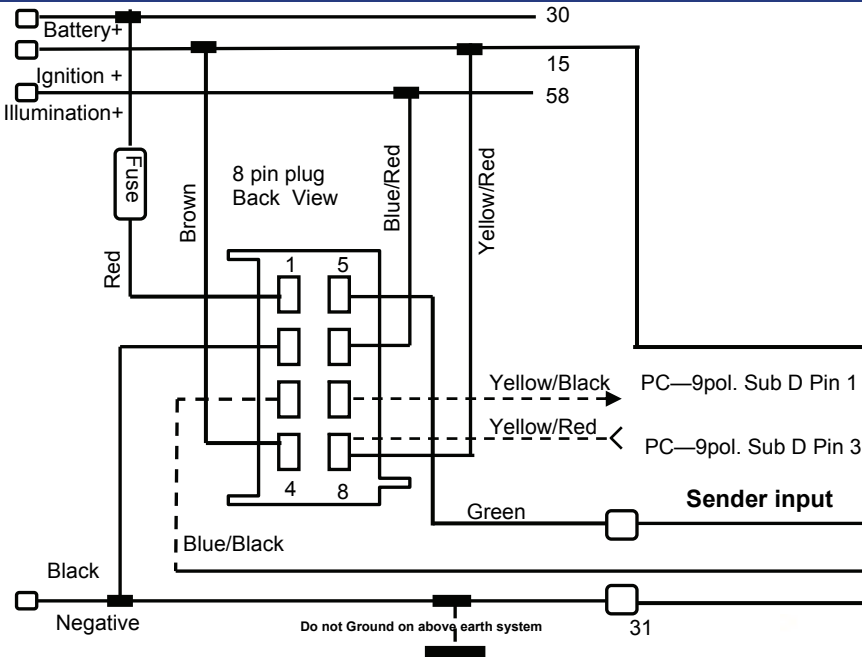

8 way connector Kit
p/n A2C59510850

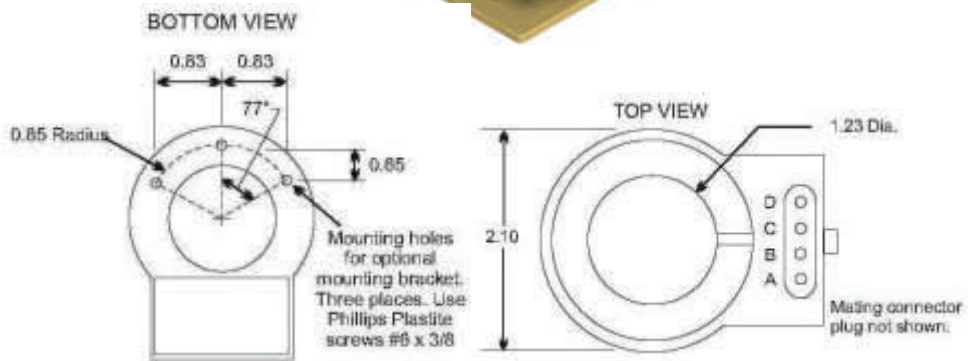
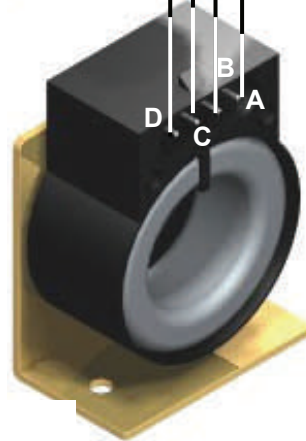

Various bracket mounting positions' example

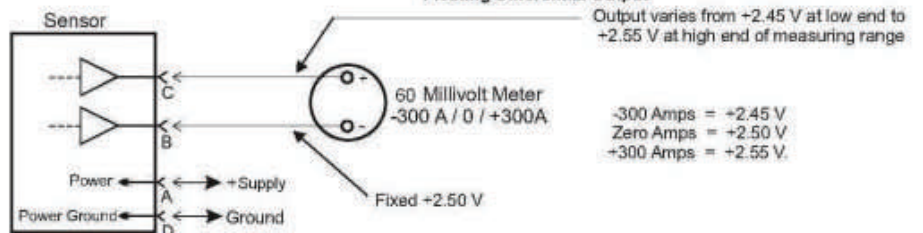
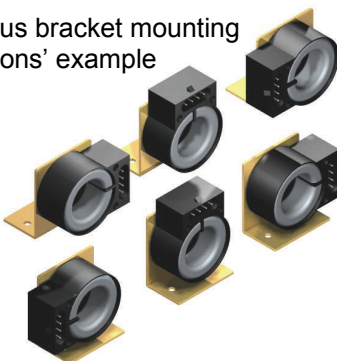

P/n **UK-UE-188** Universal Mounting Bracket Kit
P/n **UK-UE-184** Contactless Shunt Harness 3m

Ammeter with External Shunt



Ammeter Gauges 30, 60, 100 & 150 AMPS



VDO (shunt): A2C59514041, A2C59514043,
A2C59514045, A2C59514047

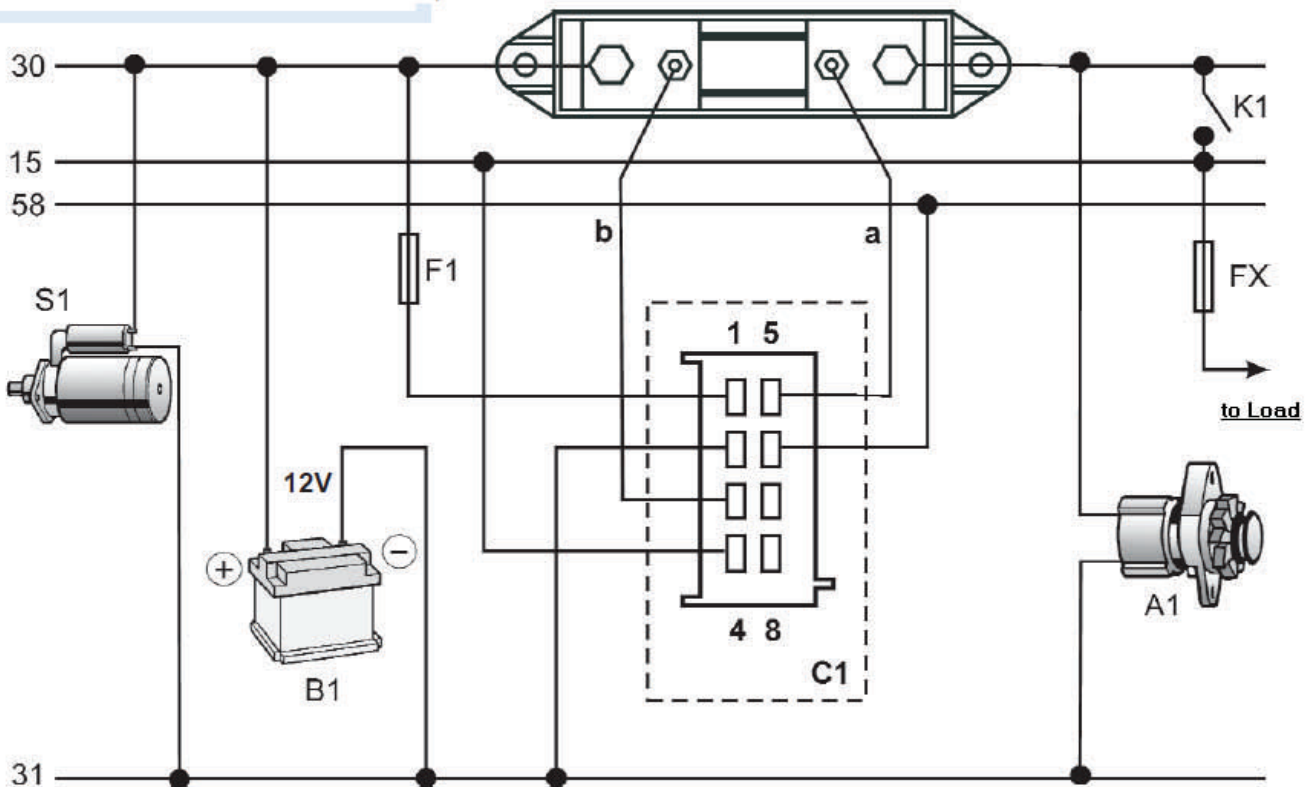

Clock wiring diagram

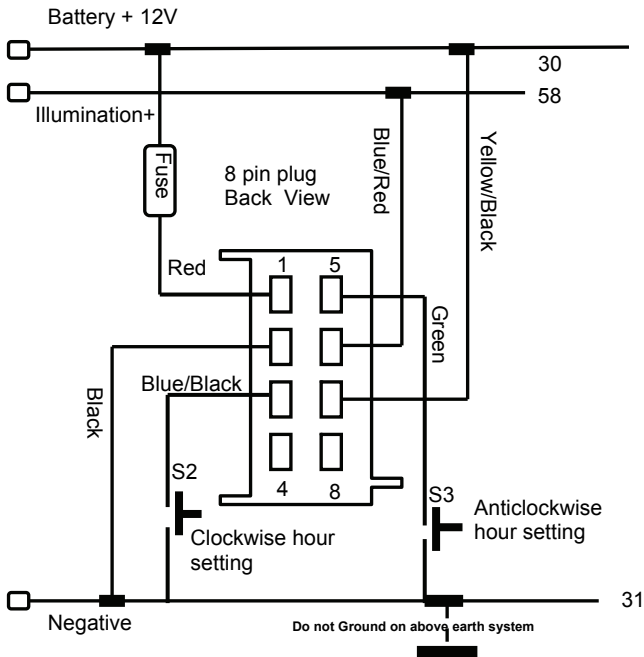

Hourmeter wiring diagram

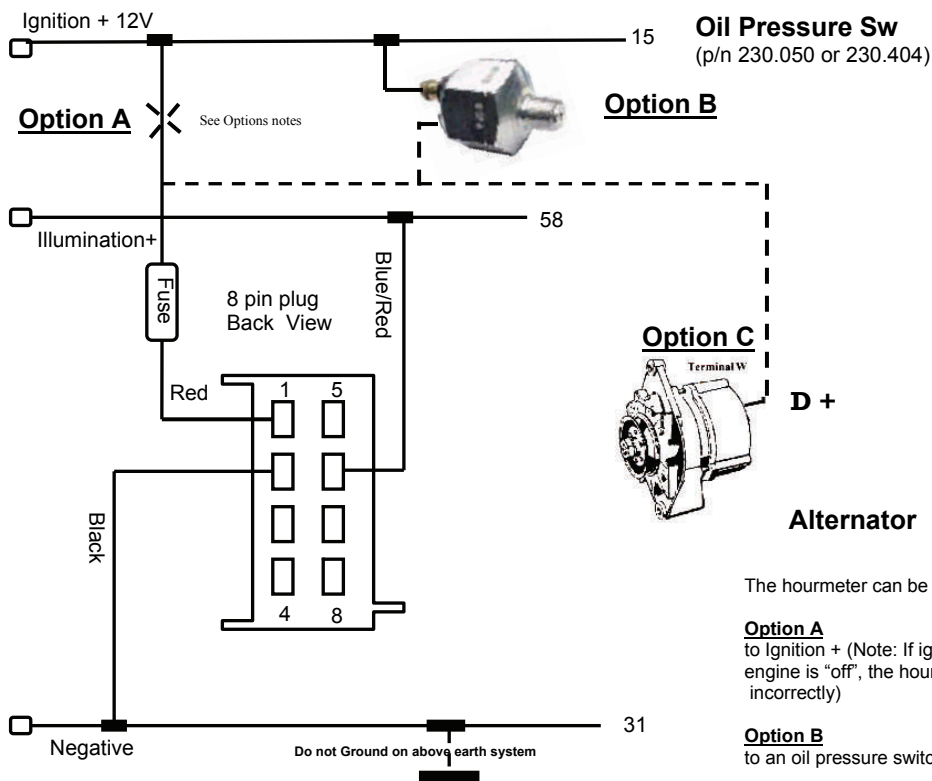

The hourmeter can be connected to a 12V supply, as follows:

Option A
to Ignition + (Note: If ignition power is let "on" and the engine is "off", the hourmeter will record engine time, incorrectly)

Option B
to an oil pressure switch (Normally "Off" contact).

Option C
to the alternator, terminal "D+"

Warning Lights



Warning Lights wiring diagram



Warning Gauge Type "A"

- Pin 1 - Term. 15, ignition plus 12V, red *
- Pin 2 - WL 6, Signal Ground, black
- Pin 3 - WL 1, Ground, blue/black
- Pin 4 - WL 2, Ground, brown
- Pin 5 - WL 3, Ground, green
- Pin 6 - WL 4, Ground, blue/red
- Pin 7 - WL 5, Ground, yellow/black
- Pin 8 - WL 6, Signal plus 12V, yellow/red

- 15 - terminal 15 - connected (ignition) plus
- 31 - terminal 31 - ground
- F1 - fuse 5A quick-response
- C1 - 8-pin MQS connector
- S1-S6 - Warning Input

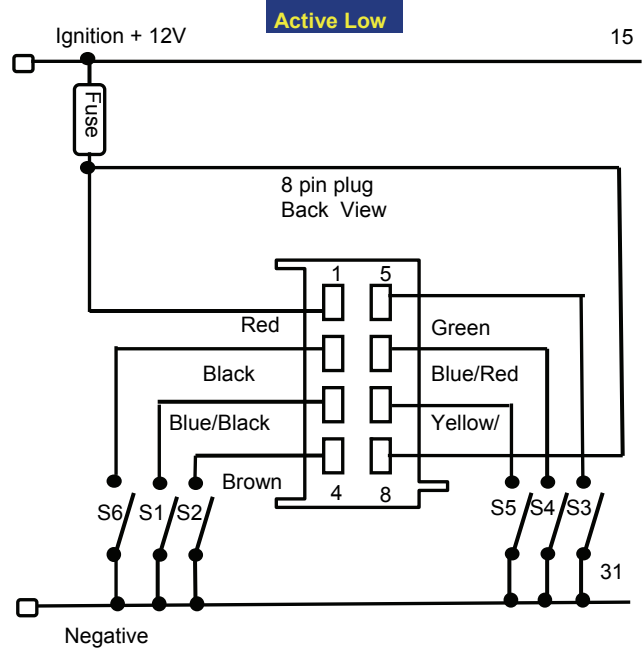
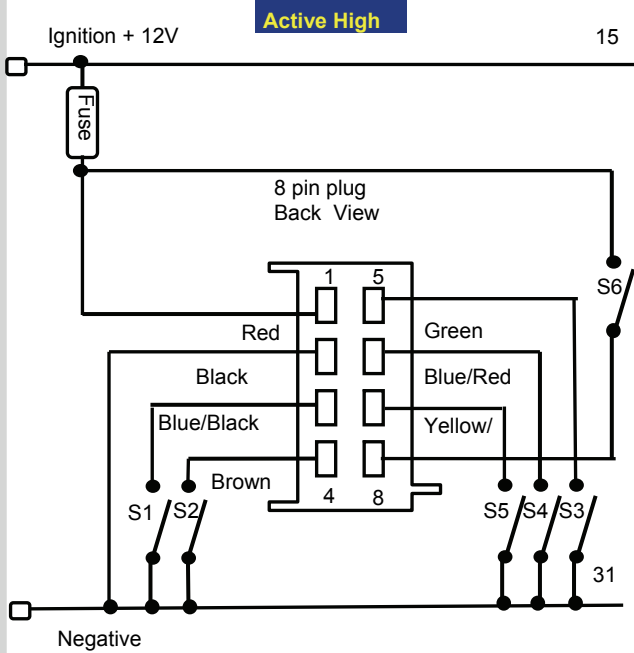

Warning Gauge Type "B"

- Pin 1 - Negative, red *
- Pin 2 - WL 6, +12V Signal, black
- Pin 3 - WL 1, +12V Signal, blue/black
- Pin 4 - WL 2, +12V Signal, brown
- Pin 5 - WL 3, +12V Signal, green
- Pin 6 - WL 4, +12V Signal, blue/red
- Pin 7 - WL 5, +12V Signal, yellow/black
- Pin 8 - WL 6, Signal plus 12V, yellow/red

- 15 - terminal 15 - connected (ignition) plus
- 31 - terminal 31 - ground
- F1 - fuse 5A quick-response
- C1 - 8-pin MQS connector
- S1-S6 - Warning Input

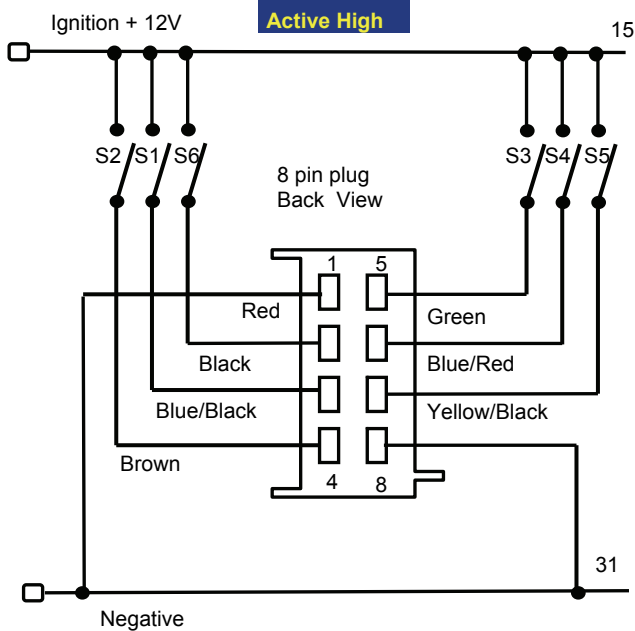

15

Electronic Alarm Switch

The Electronic Alarm Switch p/n A2C59510886 is designed to trigger the gauge's warning light at a pre-set point. It can be used on tank low level, high temp, low pressure, trim and rudder-angle. The unit has a pre-wired plug for the Viewline gauges. It operates on VDO and other manufacturers (resistive) sensors.



Specification and technical data:

- Power supply:12VDC or24VDC
- Power consumption:< 10mA (warning lamp off)
- Operation temperature:-20°C to +70°C
- EMC:CE according to EMC Law89/336/EEC
- Vibration resistance:max.1g effective25 Hz –500Hz (duration8 hours)
- Shock:15g 1,5 ms half sine

Ø52mm gauges: Can be used on Temperature, Pressure, Tank, Trim, Rudder-angle.

Ø85/110mm: for optional warning lamps (Temperature, Pressure, Tank).

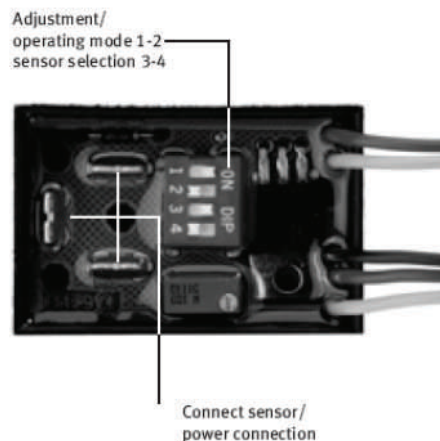

Gauges Overview



Chrome & Black Round Bezel



Chrome Triangular Bezel



Black & White Triangular Bezel



Black & White Triangular Bezel



Bezels, Accessories and gauges details

Bezels

Type	Black	Chrome	White	Size
flat	A2C53186040	A2C53186023	A2C53186022	52 mm

round	A2C53186027	A2C53186029	A2C53186028	52 mm
-------	-------------	-------------	-------------	-------

triangle	A2C53186024	A2C53186026	A2C53186025	52 mm
----------	-------------	-------------	-------------	-------

Type	Black	Chrome	White	Size
flat	A2C53192911	A2C53192910	A2C53192912	85 mm

round	A2C53192913	A2C53192914	A2C53192916	85 mm
-------	-------------	-------------	-------------	-------

triangle	A2C53192917	A2C53192918	A2C53192920	85 mm
----------	-------------	-------------	-------------	-------

Type	Black	Chrome	White	Size
flat	A2C53210745	A2C53210747	A2C53210746	110 mm

round	A2C53210749	A2C53210761	A2C53210760	110 mm
-------	-------------	-------------	-------------	--------

triangle	A2C53210763	A2C53210765	A2C53210764	110 mm
----------	-------------	-------------	-------------	--------

Accessories

Part number	Description
A2C59510854	VL Mounting Kit (studs and brackets) 52, 85, 110mm
A2C59510864	VL Mounting bracket flush mount
A2C53215641	VL Sealing Ring 85mm flush mount
A2C53215642	VL Sealing Ring 110mm flush mount
A2C59510850	Bush housing, 8-pin
A2C59510851	Bush housing, 14-pin
A2C53324664	Protective connector cap, 8-pin
A2C59513503	Adaptor cable Triducer® NMEA Sensor
A2C53324671	Protective connector cap, 14-pin
Tyco No. 539635-1	Hand pliers
Tyco No. 539682-2	Tool for hand pliers.
Tyco No. 1355718-1	Single contacts 0.14 – 0.22 mm ² tin plated
Tyco No. 963729-1	Single contacts 0.5 – 0.75 mm ² tin plated
Tyco No. 1355717-1	Strip 0.14 – 0.22 mm ² tin plated
Tyco No. 928999-1	Strip 0.25 – 0.5 mm ² tin plated
Tyco No. 963715-1	Strip 0.5 – 0.75 mm ² tin plated
Tyco No. 1355718-5	Single contacts 0.14 – 0.22 mm ² gold plated
Tyco No. 963726-5	Single contacts 0.25 – 0.5 mm ² gold plated
Tyco No. 963729-5	Single contacts 0.5 – 0.75 mm ² gold plated
Tyco No. 1355717-5	Strip 0.14 – 0.22 mm ² gold plated
Tyco No. 928999-5	Strip 0.25 – 0.5 mm ² gold plated
Tyco No. 963715-5	Strip 0.5 – 0.75 mm ² gold plated



Bezel shapes



Flush mounted



Front mounted gauges



Double lens

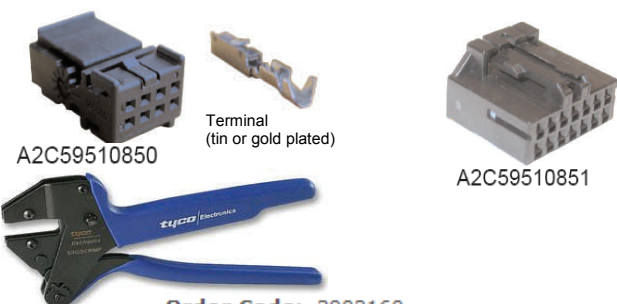

Order Code: 3902160

Manufacturer Part No: 539635-1

Order Code: 1330232

Manufacturer Part No: 539682-2

Looms and Special application devices

P/n A2C59510852 Conversion loom between Vision or International gauge and Viewline Ø 52 mm / Ø 80-85 mm gauges

Oceanline to Viewline

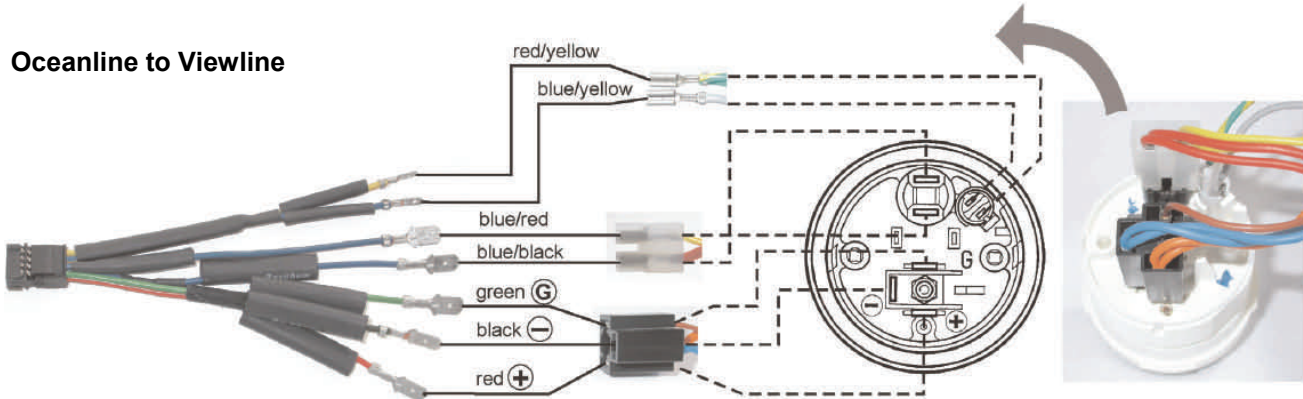

Vision & International to Viewline

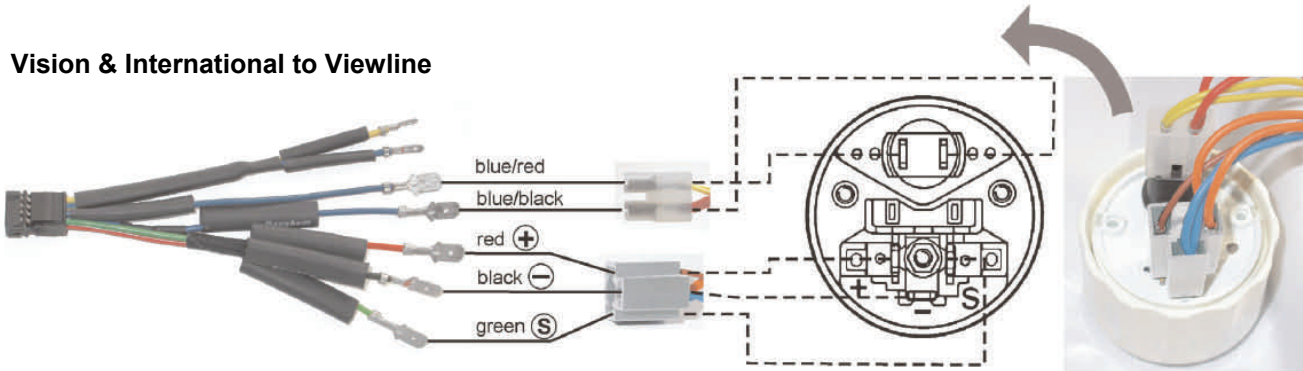

P/n A2C59512947 Harness with 8 terminals plug for Viewline Ø 52 mm / Ø 80-85 mm gauges



P/n 660.990

Over-Rev switch with single channel

The VDO RPM Switch has been designed to work with all standard ignition systems, and will provide a negative output once a predetermined RPM has been reached. In standard format the signal will turn off once the RPM falls below the pre-set point. Dip Switches are provided to program the level of hysteresis, or alternatively latch the relay on. Applications include driving a warning light or buzzer. Compatible with VDO Mega Light 600.895. 12V applications.

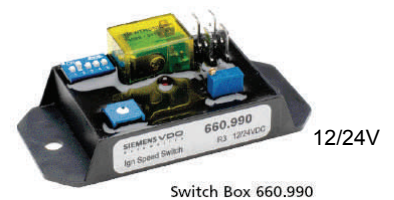

Switch Box 660.990

P/n 410.060

One channel, relay output warning switch

This module is designed to switch a 3A contact, in-built relay, at a preset voltage level. It can be used for thermatic fan, low fuel, high temp, low engine oil / transmission pressure, etc. alarm. The module can be connected to an existing sender/gauge or only to a sender.



12/24V

P/n 410.061

Three channels, warning switch

This module is designed to monitor three separate functions, by controlling three 1A transistors to switch negative when the pre-set alarm threshold is reached. It can be used to monitor/control thermatic fan, low fuel, high temp, low engine oil / transmission pressure, etc. The module can be connected to an existing sender/gauge or only to a sender.



12/24V

Signal Amplifiers, Multiplier & Dividers

P/n 411.110

Signal interface

The VDO Signal Amplifier/Divider is a general purpose module designed to convert the signal from square wave to sine wave and vice versa. It can divide as well as multiply the frequency in small steps up to three times plus or minus. Ideal for calibrating electronic boat speedo or tachometers.



12/24V

P/n 410.020

Tachourmeter active signal filter

The VDO active filter can reduce the effect of electrical noise mixed with signal. This is in situation when the electrical interference is excessive and the speedo or tacho have a pointer fluctuation (erratic reading).
Inputs: **Red** Battery +12/24V, **Orange** Ignition + 12/24V, **Green** Signal Input, **Blue** Signal Output
Note: Connector IN & OUT made to suit the VDO, Vision & International Tachourmeter

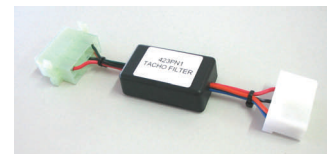

12/24V

P/n 411.096

Tachometer inductive sender, signal amplifier/Frequency Divider

The VDO Signal Amplifier/Divider is a general purpose module designed to work with most speedometer and tachometer signals. This box will amplify a low voltage signal to a 10V peak to peak square wave. This can be useful when a signal is too low to drive a speedometer, tacho, cruise control or any other such device. The signal may also be divided in frequency by a factor of 1, 2, 4, 8 or 16 to allow easier integration to another instrument.



12/24V

P/n 411.101

Over-Rev switch with two independent channels

A microprocessor controlled electronic switch module that can be programmed for a number of different functions. With two separate signal inputs switching two separate 5A relays contact the module can be a number of functions' combination. RPM, Speed Shaft rotation monitoring.

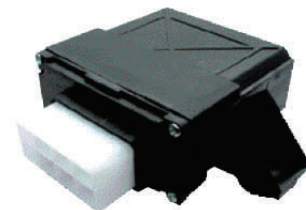

12/24V

Gauges bezel types

Ø 52 mm Gauges front fitting

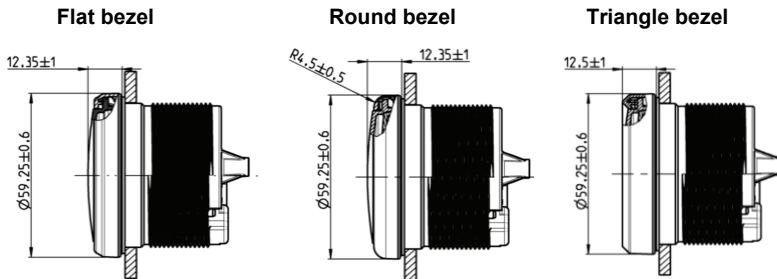

Ø 52 mm Gauges flush fitting

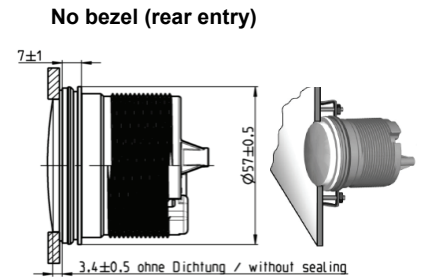

Ø 52 mm Gauge and Clamp-Ring overall dimension

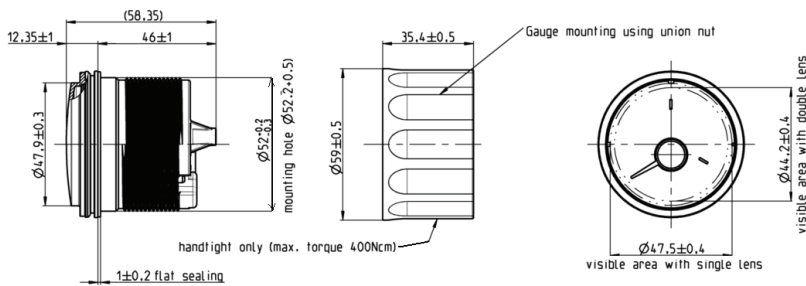

Ø 52 mm Gauges & Brackets

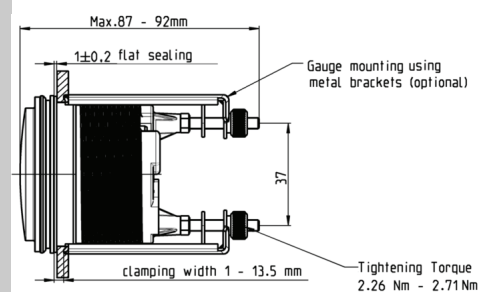

Ø 85 mm Gauges front fitting

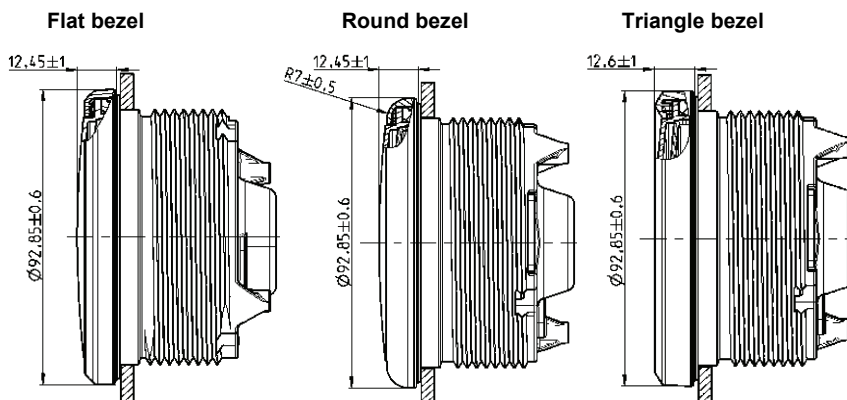

Ø 85 mm Gauges flush fitting

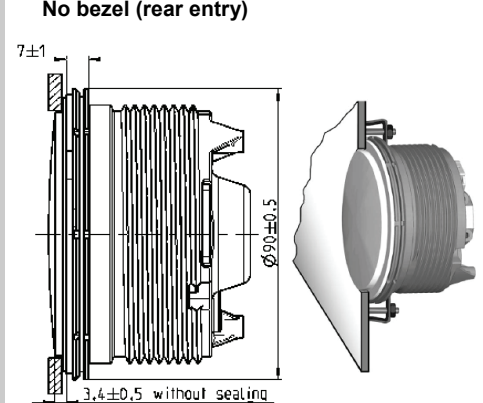

Ø 85 mm Gauge and Clamp-Ring overall dimension

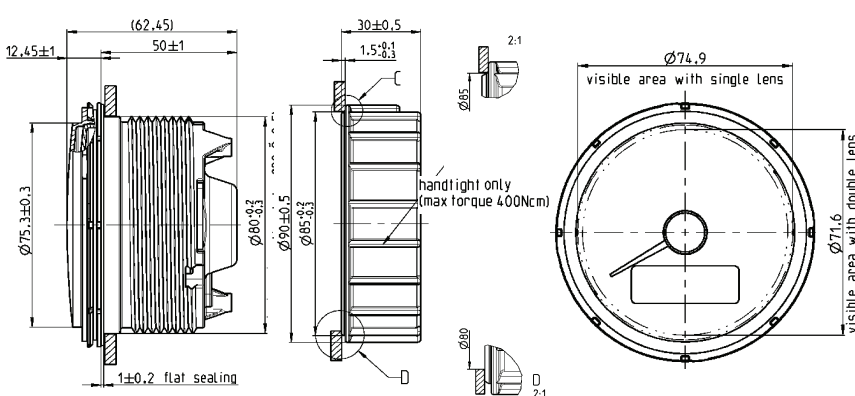

Ø 85 mm Gauges & Brackets

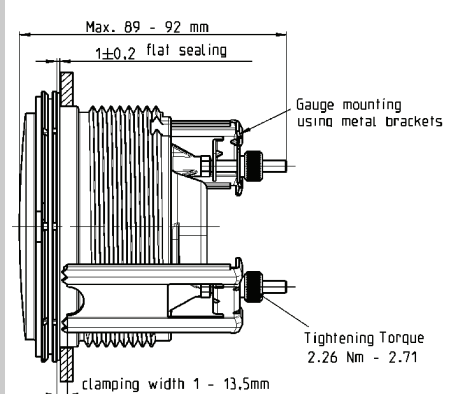

Gauges bezel types

Ø 110 mm Gauges front fitting

Flat bezel

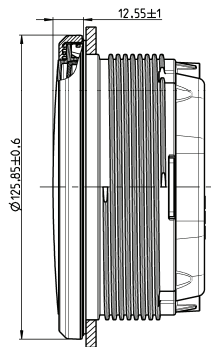

Round bezel

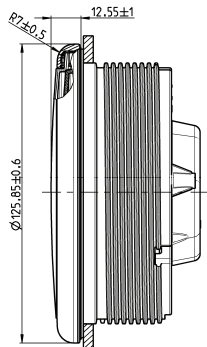

Triangle bezel

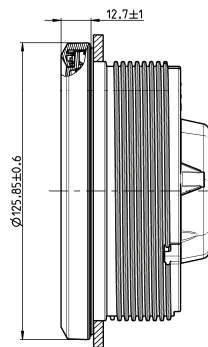

Ø 110 mm Gauges flush fitting

No bezel (rear entry)

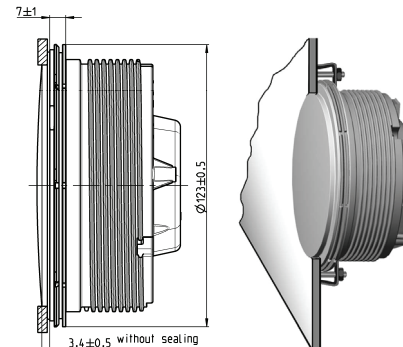

Ø 110 mm Gauge and Clamp-Ring overall dimension

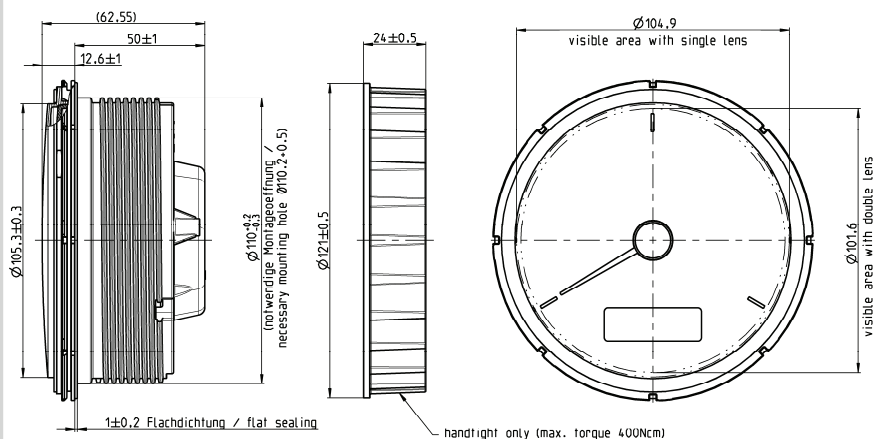

Ø 110 mm Gauges & Brackets

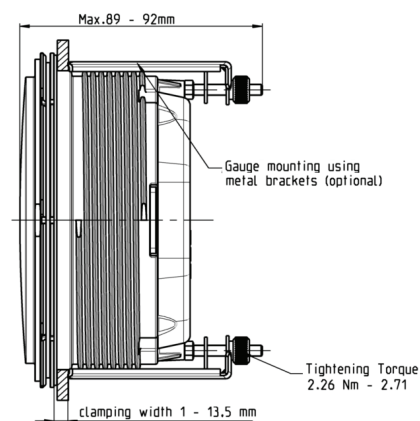

Sumlog

Technical Data

Measurement Range:	see Table
Sensors:	Sumlog SL/HS Sensor, Airmar Triducer [®] NMEA 0183
LCD-Size:	37 x 11 mm
Alarm output max:	100mA
Illumination:	amber, dimmable
Installation depth:	50mm
Installation diameter:	80 & 85mm
Deflection angle:	240°
Operating Voltage:	8,5 – 32 Volt (Sensor 8 – 16V)
Accuracy:	+/- 2,5% of full scale reading
Current consumption:	< 175 mA, including Warning LED
Operating temperature:	-20°C to +85°C; plated bezels (chrome) -20°C to +70°C
Storage temperature:	-40°C to +85°C for 48h; plated bezels (chrome) -40°C to +70°C +90°C for 1h
Temperature shock Range:	-40°C to +85°C; plated bezels (chrome) -40°C to +70°C
Transformation time:	10 seconds
Retention time:	2h
Climatic test Range:	+25°C to +55°C
Relative. Humidity:	80% to 100%
EMC:	in conformity with ISO 7637-1/2
ISO:	7637-3
ESD:	in conformity with DIN_EN 61000-4-2
ISO/CD:	10605
SAE:	J 551/15)
Vibration Sinus:	2g; 8-500Hz; duration 16h
Noise 4,2g; 10-1000Hz, duration 8h	
Mechanical shock continuous 25g; 6ms; 1Hz	
Single shock 100g; 11ms	
Free fall 1m; 3 times	
Chemical resistance against - preservative agent	
- preservative agent remover	
- cold cleaner	
- methylated spirit	
- interior cleaner	
- drinks containing caffeine and tannin	
Nominal position NL 0 to NL 85 (DIN16257)	
Protection class according to IEC 60529	
Front: IP67 (in Nominal position)	
Rear: IP52 (in Nominal position)	
Reverse polarity protection yes, 1 minute	
Short circuit protection yes, 1 minute	



Features

High reliability
Flush mount fitting
LED Illumination
Integrated Warning LED

Design

Housing PC; flame retarding (UL94)
Bezel PC or ABS; several colours and shapes (see table)
Lens PMMA; double lens
Dial backlight; different colours (see table)
Pointer backlight, white on black dials; red on white dials
Illumination Dial: LED amber (605nm)
Pointer: LED red (632nm)
Warning LED red (632nm), programmable
Mounting spin-lock Nut; locking height 0,5mm – 20mm,
optional Studs and Bracket; locking height 2 – 13mm
Connection 8 pin MQS connector system

Tachourmeter

Technical Data

Measurement Range:	see Table
Sensors:	Terminal 1 (Ignition Coil, negative side)
LCD-Size:	37 x 11 mm
Alarm output max:	100mA
Illumination:	amber, dimmable
Installation depth:	50mm
Installation diameter:	80 & 85mm
Deflection angle:	240°
Operating Voltage:	8,5 – 32 Volt (Sensor 8 – 16V)
Accuracy:	+/- 2,5% of full scale reading
Current consumption:	< 175 mA, including Warning LED
Operating temperature:	-20°C to +85°C; plated bezels (chrome)
Storage temperature:	-40°C to +85°C for 48h; plated bezels (chrome) -40°C to +70°C +90°C for 1h
Temperature shock Range:	-40°C to +85°C; plated bezels (chrome)
Relative. Humidity:	80% to 100%
Protection class	IP67 (front) in accordance to IEC 60529



Description

Gauge to indicate Engine Revolution, Engine Hours, Voltage & Clock.

Features

Integrated Warning LED
Changeable front bezel
LED Illumination
Flush mount possibility
High Reliability

Design

Housing PC; flame retarding (UL94)
Bezel PC or ABS; several colours and shapes (see table)
Lens PMMA; double lens
Dial backlight; different colours (see table)
Pointer backlight, white on black dials; red on white dials
Illumination Dial: LED amber (605nm)
Pointer: LED red (632nm)
Warning LED red (632nm), programmable
Mounting spin-lock Nut; locking height 0,5mm – 20mm,
optional Studs and Bracket; locking height 2 – 13mm
Connection 8 pin MQS connector system

(Differential Tacho)

Technical Data

Sensors:	Hall sensor Inductive sensor Blocking oscillator Ignition Terminal 1 Alternator Terminal W
Illumination:	amber, dimmable
Installation depth:	50mm
Installation diameter:	80/85mm
Deflection angle:	+/- 120°
Operating Voltage:	8,5 – 32 Volt
Accuracy:	+/- 2,5% of full scale reading
Current consumption:	< 175 mA, including Warning LED
Operating temperature:	-20°C to +85°C; plated bezels (chrome) -20°C to +70°C
Storage temperature:	-40°C to +85°C for 48h; plated bezels (chrome) -40°C to +70°C +90°C for 1h -40°C to +85°C; plated bezels (chrome) -40°C to +70°C
Temperature shock Range:	
Transformation time:	10 seconds
Retention time:	2h
Climatic test Range:	+25°C to +55°C
Relative Humidity:	80% to 100%
EMC in conformity with ISO:	7637-1/2 ISO 7637-3
ESD in conformity with DIN:	EN 61000-4-2 ISO/CD 10605
SAE:	J 551(15)
Vibration Sinus:	2g; 8-500Hz; duration 16h
Noise 4,2g; 10-1000Hz, duration 8h	
Mechanical shock continuous 25g; 6ms; 1Hz	
Single shock 100g; 11ms	
Free fall 1m; 3 times	
Chemical resistance against - preservative agent	
- preservative agent remover	
- cold cleaner	
- methylated spirit	
- interior cleaner	
- drinks containing caffeine and tannin	
Nominal position NL 0 to NL 85 (DIN16257)	
Protection class according to IEC 60529	
Front: IP67 (in Nominal position)	
Rear: IP52 (in Nominal position)	
Reverse polarity protection yes, 1 minute	



Features

High reliability
Flush mount fitting
LED Illumination
Integrated Warning LED

Concept

Housing PC; flame retarding (UL94)
Bezel PC or ABS; several colours and shapes (see table)
Lens PMMA; double lens
Dial backlight; different colours (see table)
Pointer backlight, white on black dials; red on white dials
Illumination Dial: LED amber (605nm)
Pointer: LED red (632nm)
Warning LED red (632nm), programmable
Mounting spin-lock Nut; locking height 0,5mm – 20mm,
optional Studs and Bracket; locking height 2 – 13mm
Connection 8 pin MQS connector system

Press. - Temp. - Fuel - Trim - Ammeter - Volt - Pyro – Water

Technical Specs

- 8 pole Tyco/Hirschmann MQS plug
- +/-3.6 ° angle degree accuracy over the entire display area
- Operating voltage 10–16 volt, 16–32 volt with dropping resistor
- Current consumption < 130 mA with LED warning light
- Reverse polarity protection
- Input signal: standard Ohm values
- 90 ° display angle
- 52 mm installation diameter
- Anti-fog double lens
- Front panel in compliance with IP 67 protection rating
- Red LED warning light
- Optional makepoint



Fitting $\varnothing 52$ mm gauges

To replace a bezel

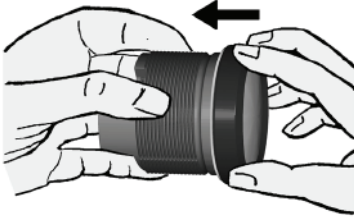

□ Place the new front ring on the instrument and press it on until it is flush with the instrument glass.



Front ring, flat; black	A2C53186040
Front ring, flat; white	A2C53186022
Front ring, flat; chrome	A2C53186023
Front ring, triangular; black	A2C53186024
Front ring, triangular; white	A2C53186025
Front ring, triangular; chrome	A2C53186026
Front ring, round; black	A2C53186027
Front ring, round; white	A2C53186028
Front ring, round; chrome	A2C53186029

To cut and fit gauge $\varnothing 52$ mm

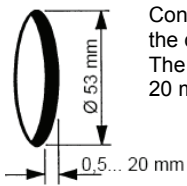

Conventional assembly. (Instrument is put into the drill hole from the front). The panel width may be within a range of 2 to 20 mm.

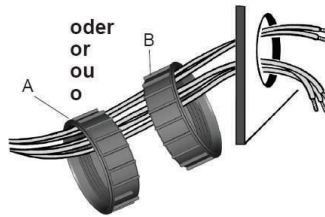

For 52 mm instruments, the fastening nut can be mounted at position A or B. This allows you to fix the gauge in different panel bores.

Version A

Clamping height 0.5 – 10 mm

Version B

Clamping height 0.5 – 20 mm

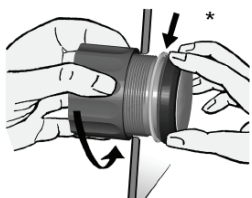

Align the instrument and hand-tighten the fastening nut. Ensure that the nut is not tightened with a torque greater than 400 Ncm.

* Make sure the seal lays flat between the panel and the front ring.

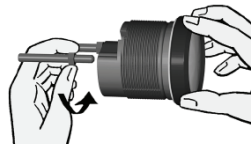

OR

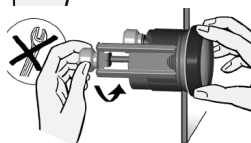

If you would like to omit the fastening nut, you may use the part set A2C59510854 as an alternative.

This is recommended if the installation location is subject to vibratory loads. Screw the stud bolts into the provided drill holes in the enclosure. Max. stud bolt torque is 1.5 Nm.

Place the bracket on the stud bolt and hand-tighten the knurled nut.

To cut and fit gauge $\varnothing 52$ mm flush mount

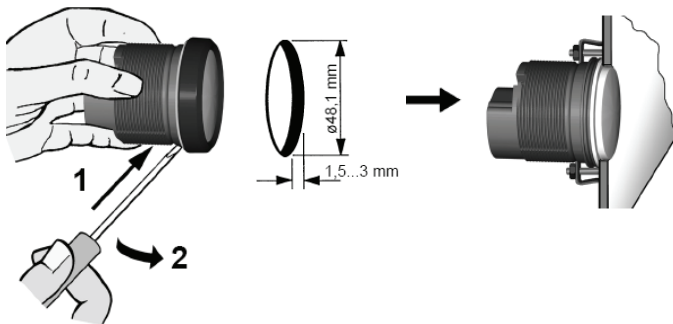

□ If the instrument is mounted flush (i. e., from the back so that the instrument glass and the panel form one plane), the front ring must be removed.

Press the instrument glass with both thumbs, while at the same time pressing the front ring forward from the instrument with both index fingers. Note the use of a tool in the adjacent figure.

□ Place the flush mount seal A2C53215640 on the instrument glass.

Put the instrument into the drill hole from the back. Adjust the instrument so that the gauge is level and fasten it to the stud bolts on the rear side of the panel, using the flush mount fixing bracket A2C59510864.

Fittings \varnothing 85mm gauges

To replace a bezel

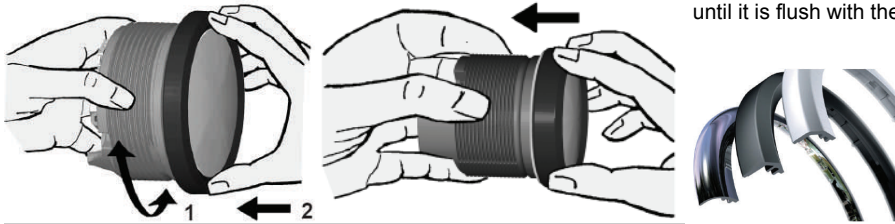

□ Place the new front ring on the instrument and press it on until it is flush with the instrument glass.

Front ring, flat; black	A2C53192911
Front ring, flat; white	A2C53192912
Front ring, flat; chrome	A2C53192910
Front ring, triangular; black	A2C53192917
Front ring, triangular; white	A2C53192920
Front ring, triangular; chrome	A2C53192918
Front ring, round; black	A2C53192913
Front ring, round; white	A2C53192916

To cut and fit gauge \varnothing 85mm

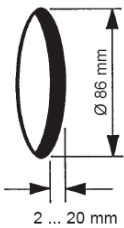

Conventional assembly. (Instrument is put into the drill hole from the front).
The panel width may be within a range of 2 to 20 mm.

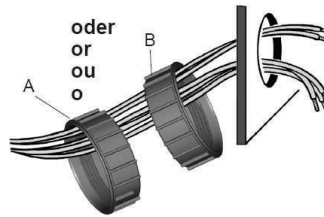

For 85 mm instruments, the fastening nut can be mounted at position A or B. This allows you to fix the gauge in different panel bores.

Version A Panel bore **80.5 - 81 mm**
Circumferential lip away from instrument

Version B Panel bore **85.5 - 86 mm**
Circumferential lip next to instrument

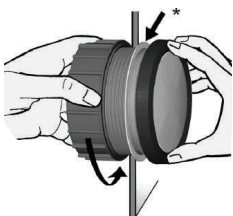

Align the instrument and hand-tighten the fastening nut. Ensure that the nut is not tightened with a torque greater than 400 Ncm.
* Make sure the seal lays flat between the panel and the front ring.

OR

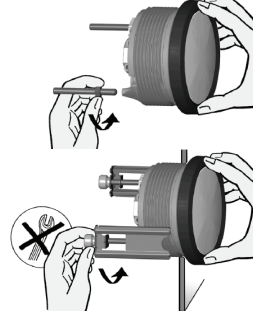

If you would like to omit the fastening nut, you may use the part set A2C59510854 as an alternative. This is recommended if the installation location is subject to vibratory loads. Screw the stud bolts into the provided drill holes in the enclosure. Max. stud bolt torque is 1.5 Nm.

Place the bracket on the stud bolt and hand-tighten the knurled nut.

To cut and fit gauge \varnothing 85mm flush mount

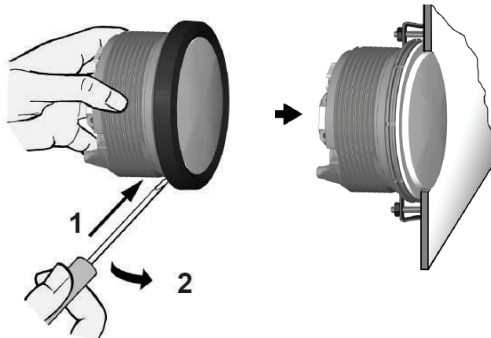
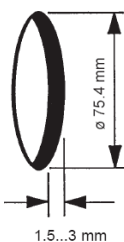

□ If the instrument is mounted flush (i. e., from the back so that the instrument glass and the panel form one plane), the front ring must be removed.

Press the instrument glass with both thumbs, while at the same time pressing the front ring forward from the instrument with both index fingers. Note the use of a tool in the adjacent figure.

□ Place the flush mount seal A2C53215641 on the instrument glass.

Put the instrument into the drill hole from the back. Adjust the instrument so that the gauge is level and fasten it to the stud bolts on the rear side of the panel, using the flush mount fixing bracket A2C59510864.

To unplug connector

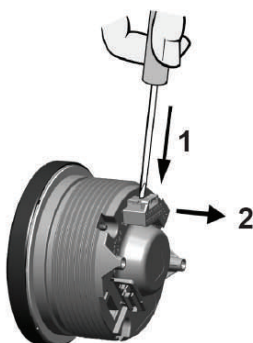

To remove the connector, press the latch (1) and pull the connector out (2).

Note: \varnothing 110 Gauges require a panel bore of \varnothing 111 mm.
Panel width may be within a range of 2 and 20 mm
Flush mount seal is p/n A2C53215642

Sumlog Calibration

Calibration for:

- Hall Effect Output Transducer

For NMEA Transducer Change "Input" to NMEA. No pulse calibration needed.

- ◆ Press the key briefly (< 2sec.) to change the currently displayed value.
- ◆ Press the key longer (< 2sec.) to change to the next value.
The display returns to normal operating mode (if a key is not pressed for 30 seconds. Any settings

To enter calibration mode



- ◆ Press and hold Configuration Key

Press the Config key to change over between the "Frequency" input (8 pole plug pin 5) and the NMEA0183 input (14 pole plug, pin 1 & 2)

- ◆ Press Configuration Key briefly

- ◆ Press and hold Configuration Key

Set impulses number is displayed.
The first digit flashes.

- ◆ Press Configuration Key briefly

The flashing digit increases by 1.
If the flashing digit is "9", the display returns to "0".

- ◆ Press Config key briefly

The next lower digit flashes

- ◆ Press Config key briefly

Deactivate Ignition power.
This saves the impulse number in the display.
Continue until the complete impulse number is set

- ◆ Press and hold Config key

Deactivate Ignition power (T15).
This saves the impulse number in the display.

Sumlog Alarm Threshold

Setting of unit and Alarm Threshold

- ◆ Battery Power **On** T. 30 (8-pin - Pin1)
- ◆ Ignition Power **Off** T. 15 (8-pin - Pin4)
- ◆ Press and hold Mode key (14-pin - Pin 12)

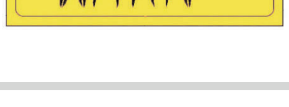
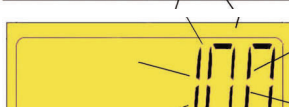
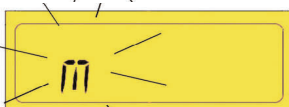
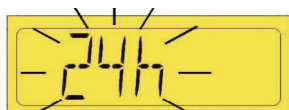

- ◆ Ignition Power **On** T. 15
- ◆ Release Mode key
- ◆ Press and hold Mode Key

By briefly pressing the Mode key, you can switch between 24h and 12h (AM/PM) clock format.

- ◆ Press and hold Mode key
- Press the Mode key to change the water temperature unit from °C to °F.

- ◆ Press and hold Mode key
- Press Mode key briefly to change the water depth unit from von m to ft.

- ◆ Press and hold Mode key

- ◆ Press and hold Mode key

- ◆ Press and hold Mode key

Set alarm threshold is displayed; the first digit flashes.

- ◆ Press Mode key briefly

The flashing digit increases by 1. If the flashing digit is "9", the display returns to "0".

- ◆ Press and hold Mode key

The next lower digit flashes in the display.

- ◆ Press Mode key briefly

The flashing digit increases by 1. If the flashing digit is "9", the display returns to "0".

Continue until the complete alarm threshold is set.

- ◆ Press and hold Mode key

Switch **Off** Ignition power (T15).

This saves the unit and the alarm threshold in the display.

Sumlog Operation

Display Selection

- ◆ Switch **On** Battery Power T. 30 (8-pin - Pin1)
- ◆ Switch **On** Ignition Power T. 15 (8-pin - Pin4)

Odometer



- ◆ Press and hold Mode Key

Tripmeter



- ◆ Press and hold Mode key

Depth



- ◆ Press and hold Mode key

Time



- ◆ Press and hold Mode key

Water temperature



- ◆ Press and hold Mode key

Battery voltage



Resetting Trip Counter

- ◆ Switch **On** Battery Power T. 30 (8-pin - Pin1)
- ◆ Switch **On** Ignition Power T. 15 (8-pin - Pin4)

Press the Mode key repeatedly until the trip distance are displayed.



- ◆ Press and hold Mode key



- ◆ Trip is now deleted

Sumlog Clock & LCD Brightness Function

Setting the Clock

- ◆ Battery Power **On** T. 30 (8-pin - Pin1)
- ◆ Ignition Power **On** T. 15 (8-pin - Pin4)
- ◆ Press the Mode key repeatedly until the time is displayed
- ◆ Press and hold Mode key

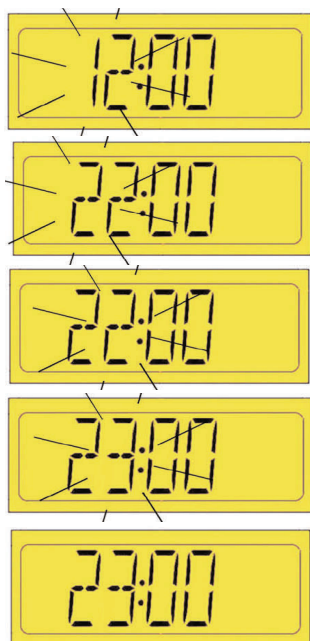

Set time is displayed; the first digit flashes.

- ◆ Press Mode key briefly

The flashing digit increases by 1. If the flashing digit is "9", the display returns to "0"

- ◆ Press and hold Mode key

The next lower digit flashes.

- ◆ Press Mode key briefly

The flashing digit increases by 1. If the flashing digit is "9", the display returns to "0".

Continue until the correct time is set

- ◆ Press and hold Mode key

Setting the Brightness

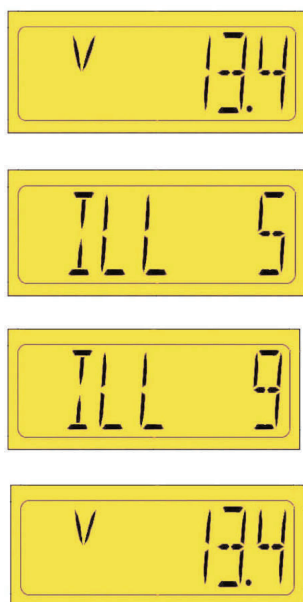

- ◆ Battery Power **On** T. 30 (8-pin - Pin1)
- ◆ Ignition Power **On** T. 15 (8-pin - Pin4)
- ◆ Press the Mode key repeatedly until the Voltmeter is displayed.

- ◆ Press Mode key briefly

- ◆ Press the Mode key repeatedly until the desired brightness is reached. The brightness can be set between 0 (OFF) to 10 (max).

- ◆ Press and hold Mode key

- ◆ The desired brightness is now permanently set.

Tachourmeter Calibration

Setting impulses / revolution

- ◆ Battery Power **On** T. 30 (8-pin - Pin1)
- ◆ Ignition Power **Off** T. 15 (8-pin - Pin4)
- ◆ Press and hold Configuration key (14-pin - Pin 12)

To enter calibration mode

- ◆ Ignition Power **On** T. 15
- ◆ Release Configuration key



- ◆ Press and hold Configuration Key

Set impulse number is displayed, the first digit flushes.

- ◆ Press Configuration key briefly

The flushing digit increases by 1. If the flushing digit is "9", the display returns to "0"

- ◆ Press and hold Configuration Key

The next lower digit flushes

- ◆ Press Configuration Key briefly

The flushing digit increases by 1.
If the flushing digit is "9", the display returns to "0".
Continue until the complete impulse number is set

- ◆ Press and hold Configuration Key

Deactivate Ignition power T.15
This saves the impulse number in the display.

Disconnect and reconnect the 8 Pin Plug once the calibration is done.

Tachourmeter Calibration

Setting the unit and alarm threshold

- ◆ Battery Power **On** T. 30 (8-pin - Pin1)
- ◆ Ignition Power **Off** T. 15 (8-pin - Pin4)
- ◆ Press and hold Mode key (14-pin - Pin 12)
- ◆ Ignition Power **On** T. 15
- ◆ Release Mode key



- ◆ Press and hold Mode key

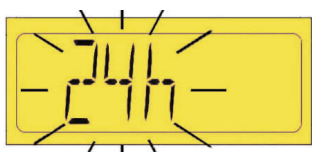

By briefly pressing the Mode key, you can switch between 24h and 12h (AM/PM) clock format.

- ◆ Press and hold Mode key



- ◆ Press Mode key briefly



- ◆ Press and hold Mode key



Set alarm threshold is displayed; the first digit flashes.

- ◆ Press Mode key briefly



The flashing digit increases by 1. If the flashing digit is "9", the display returns to "0"

- ◆ Press Mode key briefly

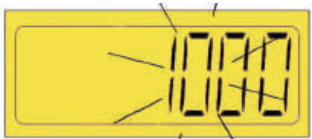

Set alarm threshold is displayed; the first digit flashes.

- ◆ Press Mode key briefly

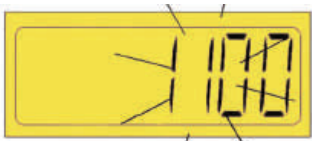

The flashing digit increases by 1. If the flashing digit is "9", the display returns to "0"

- ◆ Press and hold Mode key



Ignition Power **Off** T. 15.

This saves the unit and the alarm threshold in the display.

Tachourmeter Calibration

In operation Display indicator selection

- ◆ Battery Power **On** T. 30 (8-pin - Pin1)
- ◆ Ignition Power **On** T. 15 (8-pin - Pin4)

Total operating  hours

- ◆ Press Mode key briefly

Trip hours 

- ◆ Press Mode key briefly

Time 

- ◆ Press Mode key briefly

Vehicle voltage 

- ◆ Press Mode key briefly

Resetting the day counter

- ◆ Battery Power **On** T. 30 (8-pin - Pin1)
- ◆ Ignition Power **On** T. 15 (8-pin - Pin4)

Press the Mode key repeatedly until the trip hours are displayed.



- ◆ Press and hold Mode key



- ◆ Trip is now deleted.

Tachourmeter Calibration

Setting the Clock

- ◆ Battery Power **On** T. 30 (8-pin - Pin1)
- ◆ Ignition Power **On** T. 15 (8-pin - Pin4)
- ◆ Press the Mode key repeatedly until the time is displayed
- ◆ Press and hold Mode key



Set time is displayed; the first digit flashes.

- ◆ Press Mode key briefly

The flashing digit increases by 1. If the flashing digit is "9", the display returns to "0"

- ◆ Press and hold Mode key

The next lower digit flashes.

- ◆ Press Mode key briefly

The flashing digit increases by 1. If the flashing digit is "9", the display returns to "0".

Continue until the correct time is set

- ◆ Press and hold Mode key

Setting the Brightness

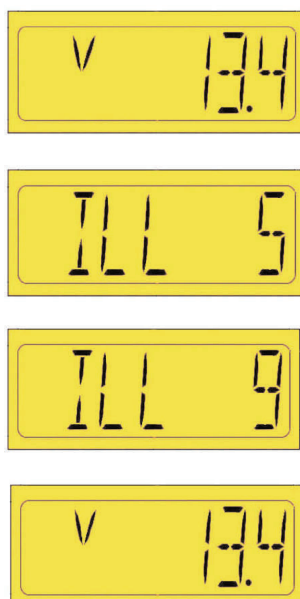

- ◆ Battery Power **On** T. 30 (8-pin - Pin1)
- ◆ Ignition Power **On** T. 15 (8-pin - Pin4)
- ◆ Press the Mode key repeatedly until the Voltmeter is displayed.

- ◆ Press Mode key briefly

- ◆ Press the Mode key repeatedly until the desired brightness is reached. The brightness can be set between 0 (OFF) to 10 (max).

- ◆ Press and hold Mode key

- ◆ The desired brightness is now permanently set.

Part Number Index



Part No.	Page	Part No.	Page	Part No.	Page	Part No.	Page
220.004	24	220.660-180	25	323801001008N	33	323805001015N	33
220.005	24	224011000015G	22	323801001009N	33	360081030014C	31
230.041	32	224011000016G	22	323801001010K	33	360081030001K	31
230.044	32	224011000017G	22	323801001022K	33	360081030002K	31
230.050	26	224011000017G	24	323801001040N	33	360081030009K	32
230.050	32	224011000018G	22	323801010001D	33	360081030015C	32
230.701	32	224011000019G	22	323803001002D	33	360081030017C	32
230.990	32	224011000020G	22	323803001004D	33	360081030022C	32
230.993	32	224011000021G	22	323803001006D	33	360081030028K	31
240.035	16	224011000022G	22	323803001008D	33	360081030039C	32
320.714	16	224011000023G	22	323803001011D	33	360081030049K	31
360.001	31	224011000024G	22	323803001012D	33	360081030052C	32
360.004	31	224011000025G	22	323803001013D	33	360081032001C	31
360.016	31	224011000026G	22	323803001019D	33	360081032002C	31
1501120004	12	224011000027G	22	323803004002D	33	360081032006C	22
22502641141	24	224011000028G	22	323805001001K	33	360081032011C	21
230112005006	32	224011000029G	22	323805001002C	33	360081032014C	22
230213002001	32	224011000030G	22	323805001004K	33	360081032025C	31
230213002004	32	224011000031G	22	323805001005N	33	360081032025C	21
220.150-180	21	226801015001C	16	323805001007N	33	360081038001C	23
220.150-180	25	232011005004D	34	323805001015N	33	360081038001C	23
220.180-180	21	232011005027D	34	323805002007D	33	360081038002C	23
220.180-180	25	232011005030D	34	323805003001N	33	360081038002C	23
220.230-180	21	232011017004D	34	323805003002N	33	360081038003C	23
220.230-180	25	232011017009D	34	325801002002D	33	360081038003C	23
220.250-180	21	232011017010D	34	325805003001C	33	360081039002C	31
220.260-180	21	232011017016D	34	325805003002C	33	360081039003C	32
220.260-180	25	232011017017D	34	323805001001K	15	360081039004C	31
220.270-180	21	232011017032D	34	323805001001K	30	362081001001K	31
220.270-180	25	232011017034D	34	323805001001K	33	362081001002K	31
220.300-180	21	232011017038D	34	323805001002C	15	362081002001K	31
220.300-180	25	232011017080D	34	323805001002C	33	362081003002K	31
220.320-180	21	232011017087D	34	323805001004K	15	362081004001C	31
220.320-180	25	232011017099D	34	323805001004K	30	395024004008C	31
220.330-180	21	232011017103D	34	323805001005N	30		
220.330-180	25	232011017131D	34	323805001005N	33		
220.350-180	21	232011017148D	34	323805001007N	15		
220.600-180	21	232011019003D	34	323805001007N	33		
220.600-180	25	323801001006K	33	323805001015N	15		
220.660-180	21	323801001007N	33	323805001015N	30		

Part Number Index



Part No.	Page	Part No.	Page	Part No.	Page	Part No.	Page
440102001001D	28	A2C59512459	27	UK-UE-188	27		
440102002001D	28	A2C59512545	27	X10224000007	31		
A2C59510165	36	A2C59512546	27	X10232001001	31		
A2C59510166	20	A2C59513443	28	X10232001002	31		
A2C59510166	24	A2C59513444	28	X10232001003	30		
A2C59510166	36	A2C59513445	28	X10232001004	34		
A2C59510167	20	A2C59513446	28	X10232001005	34		
A2C59510167	24	A2C59514088	22	X10232001006	34		
A2C59510167	36	A2C59514094	28	X10232001007	34		
A2C59510171	20	A2C59514085	28	X10232001008	34		
A2C59510171	24	A2C59514184	24	X10232001009	34		
A2C59510171	36	A2C59514184	25	X10232001010	34		
A2C59510172	20	A2C59514182	20				
A2C59510172	24	A2C59514182	21				
A2C59510172	36	A2C59514190	24				
A2C59510173	20	A2C59514186	24				
A2C59510173	24	A2C59514170	15				
A2C59510173	36	A2C59514160	15				
A2C59512332	16	A2C59514237	15				
A2C59512333	16	A2C59514231	15				
A2C59512334	16	A2C59514149	17				
A2C59512335	16	A2C59514123	18				
A2C59512336	16	A2C59514111	18				
A2C59512344	13	A2C59514136	19				
A2C59512345	13	A2C59514141	19				
A2C59512346	13	A2C59514225	17				
A2C59512347	13	A2C59514211	17				
A2C59512348	13	A2C59514199	17				
A2C59512349	13	A2C59514206	19				
A2C59512396	13	A2C59514208	19				
A2C59512397	13	A2C59512328	31				
A2C59512398	13	A2C59512329	31				
A2C59512399	13	A2C59512330	31				
A2C59512402	14	A2C59512331	31				
A2C59512403	14	A2C59512342	30				
A2C59512410	28	A2C59512343	30				
A2C59512411	28	CTA0200Kit	28				
A2C59512453	26	UK-UE-094	27				
A2C59512454	26	UK-UE-157	27				
A2C59512458	27	UK-UE-184	27				

Warranty Policy

Continental Pty Ltd (VDO) warrants the goods against defects in factory workmanship and materials within the warranty period.

The warranty period for automotive, commercial and marine products shall be 24 months from the date of invoice, subject to the usage limitation of 100,000 Km for goods installed in commercial vehicles.

The warranty period for audio and navigation products shall be 24 months from date of invoice.

The warranty period for repaired items shall be 90 days from the date of invoice.

The customer must notify the point of purchase / distributor of any defect coming within the provisions of this warranty within 30 days of the fault occurring.

A copy of the relevant invoice or the relevant invoice number as proof of the date of purchase must be provided with returned goods.

Continental P/L (VDO) liability with respect to this warranty shall be limited at the option of Continental P/L (VDO) to repair or replacement of the goods.

Removal and refitting costs and all freight costs associated with the warranty claims are the responsibility of the customer.

This warranty shall not apply to goods which have been opened by a third party. Contaminated by oil, water or grease, fitted in excessive vibration environments or improperly connected.

Glass and capillary breakages are excluded from the provisions of this warranty.

Save and except for the express warranty set out above and to the maximum extent permitted by law, all conditions and warranties which may at the time be implied by common law, Trade Practices Act, Fair Trading Act, Goods Act or any other state or Federal Act are excluded.

To the extent that these cannot be excluded and where the law permits.

Continental's liability in respect of any such condition or warranty, shall be limited at the option of Continental P/L (VDO) to repair or replacement of the goods or the supply of equivalent goods or the payment of the costs of the replacing or repairing the goods, or having them replaced or repaired.

Flavio 07022014

The information provided in this brochure contains only general descriptions or performance characteristics, which do not always apply as described in case of actual use or which may change as a result of further development of the products. This information is merely a technical description of the product. This information is not meant or intended to be a special guarantee for a particular quality or a particular durability. An obligation to provide the respective characteristics shall only exist if expressly agreed in the terms of contract. We reserve the right to make changes in availability as well as technical changes without prior notice.

